

UNIFIED FACILITIES CRITERIA (UFC)

DESIGN: CHAPELS AND RELIGIOUS EDUCATION FACILITIES



APPROVED FOR PUBLIC RELEASE; DISTRIBUTION UNLIMITED

UNIFIED FACILITIES CRITERIA (UFC)

DESIGN: CHAPELS AND RELIGIOUS EDUCATION FACILITIES

Any copyrighted material included in this UFC is identified at its point of use.
Use of the copyrighted material apart from this UFC must have the permission of the
copyright holder.

U.S. ARMY CORPS OF ENGINEERS

NAVAL FACILITIES ENGINEERING COMMAND (Preparing Activity)

AIR FORCE CIVIL ENGINEERING SUPPORT AGENCY

Record of Changes (changes indicated by \1\ ... /1/)

<u>Change No.</u>	<u>Date</u>	<u>Location</u>

FOREWORD

The Unified Facilities Criteria (UFC) system is prescribed by MIL-STD 3007 and provides planning, design, construction, sustainment, restoration, and modernization criteria, and applies to the Military Departments, the Defense Agencies, and the DoD Field Activities in accordance with [USD\(AT&L\) Memorandum](#) dated 29 May 2002. UFC will be used for all DoD projects and work for other customers where appropriate. All construction outside of the United States is also governed by Status of forces Agreements (SOFA), Host Nation Funded Construction Agreements (HNFA), and in some instances, Bilateral Infrastructure Agreements (BIA.) Therefore, the acquisition team must ensure compliance with the more stringent of the UFC, the SOFA, the HNFA, and the BIA, as applicable.

UFC are living documents and will be periodically reviewed, updated, and made available to users as part of the Services' responsibility for providing technical criteria for military construction. Headquarters, U.S. Army Corps of Engineers (HQUSACE), Naval Facilities Engineering Command (NAVFAC), and Air Force Civil Engineer Support Agency (AFCESA) are responsible for administration of the UFC system. Defense agencies should contact the preparing service for document interpretation and improvements. Technical content of UFC is the responsibility of the cognizant DoD working group. Recommended changes with supporting rationale should be sent to the respective service proponent office by the following electronic form: [Criteria Change Request \(CCR\)](#). The form is also accessible from the Internet sites listed below.

UFC are effective upon issuance and are distributed only in electronic media from the following source:

- Whole Building Design Guide web site <http://dod.wbdg.org/>.

Hard copies of UFC printed from electronic media should be checked against the current electronic version prior to use to ensure that they are current.

AUTHORIZED BY:



DONALD L. BASHAM, P.E.
Chief, Engineering and Construction
U.S. Army Corps of Engineers



DR. JAMES W. WRIGHT, P.E.
Chief Engineer
Naval Facilities Engineering Command

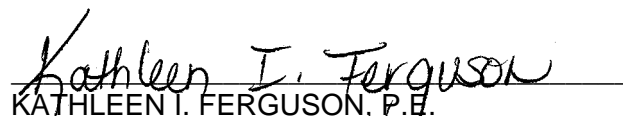

KATHLEEN I. FERGUSON, P.E.
The Deputy Civil Engineer
DCS/Installations & Logistics
Department of the Air Force

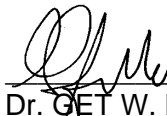

Dr. GET W. MOY, P.E.
Director, Installations Requirements and
Management
Office of the Deputy Under Secretary of Defense
(Installations and Environment)

CONTENTS

	Page
CHAPTER 1 INTRODUCTION	
Paragraph 1-1 PURPOSE AND SCOPE	1-1
1-2 APPLICABILITY	1-1
1-2.1 General Building Requirements	1-1
1-2.2 Safety	1-1
1-2.3 Fire Protection	1-1
1-2.4 Antiterrorism/Force Protection	1-1
1-3 AIR FORCE CRITERIA	1-1
1-4 ARMY CRITERIA.....	1-2
APPENDIX A DESIGN MANUAL 37.6.....	A-1

CHAPTER 1

INTRODUCTION

1-1 **PURPOSE AND SCOPE.** This UFC is comprised of two sections. Chapter 1 introduces this UFC and provides a listing of references to other Tri-Service documents closely related to the subject. Appendix A contains the full text copy of the previously released Design Manual (DM) on this subject. This UFC serves as criteria until such time as the full text UFC is developed from the Design Manual and other sources.

This UFC provides general criteria for designing chapels and religious education facilities.

Note that this document does not constitute a detailed technical design, and is issued as a general guide to the considerations associated with designing chapels and religious education facilities.

1-2 **APPLICABILITY.** This UFC applies to all Navy agencies and contractors designing chapels and religious education facilities.

1-2.1 **GENERAL BUILDING REQUIREMENTS.** All DoD facilities must comply with UFC 1-200-01, *Design: General Building Requirements*. If any conflict occurs between this UFC and UFC 1-200-01, the requirements of UFC 1-200-01 take precedence.

1-2.2 **SAFETY.** All DoD facilities must comply with DODINST 6055.1 and applicable Occupational Safety and Health Administration (OSHA) safety and health standards.

NOTE: All **NAVY** projects, must comply with OPNAVINST 5100.23 (series), *Navy Occupational Safety and Health Program Manual*. The most recent publication in this series can be accessed at the NAVFAC Safety web site:

www.navfac.navy.mil/safety/pub.htm. If any conflict occurs between this UFC and OPNAVINST 5100.23, the requirements of OPNAVINST 5100.23 take precedence.

1-2.3 **FIRE PROTECTION.** All DoD facilities must comply with UFC 3-600-01, *Design: Fire Protection Engineering for Facilities*. If any conflict occurs between this UFC and UFC 3-600-01, the requirements of UFC 3-600-01 take precedence.

1-2.4 **ANTITERRORISM/FORCE PROTECTION.** All DoD facilities must comply with UFC 4-010-01, *Design: DoD Minimum Antiterrorism Standards for Buildings*. If any conflict occurs between this UFC and UFC 4-010-01, the requirements of UFC 4-010-01 take precedence.

1-3 **AIR FORCE CRITERIA.** Air Force agencies and contractors should refer to the Air Force Religious Facility Design Guide at:
<http://afcee.brooks.af.mil/dc/dcd/ARCH/religious/index.html>.

1-4 **ARMY CRITERIA.** Army agencies and contractors should contact the Huntsville Tech Info POC as listed at the Huntsville USACE website:
<http://www.hnd.usace.army.mil/techinfo>.

APPENDIX A

**DESIGN MANUAL 37.6
CHAPELS AND RELIGIOUS EDUCATION FACILITIES**

CCB Application Notes:

1. Character(s) preceded & followed by these symbols ([^]) or (_~) are super- or subscripted, respectively.
EXAMPLES: 42m³ = 42 cubic meters
CO₂ = carbon dioxide
2. All degree symbols have been replaced with the word deg.
3. All plus or minus symbols have been replaced with the symbol +/-.
4. All table note letters and numbers have been enclosed in square brackets in both the table and below the table.
5. Whenever possible, mathematical symbols have been replaced with their proper name and enclosed in square brackets.

Naval Facilities Engineering Command
200 Stoval Street
Alexandria, Virginia 22332-2300

APPROVED FOR PUBLIC RELEASE

Chapels &
Religious Educational
Facilities

Design Requirements
& Functional Analyses

SEPTEMBER 1985

ABSTRACT

Design guidance for the planning of chapels, facility category 730-83, and religious educational facilities, facility category 730-84, for the naval services on military bases is presented for use by experienced architects and engineers. A statement of the intentions and activities of the religious program is followed by a discussion of the differences between such facilities in the military and in the civilian circumstance and notations on those qualities of architectural that qualify it as religion-related. Criteria for site selection and an analysis of building functions are identified. The organization of building elements for facilities of various sizes is studied and is followed by discussion of special technical data. Furniture, artifacts and symbolic devices are identified and described, and the processes of their acquisition indicated.

PAGE iii INTENTIONALLY BLANK

FOREWORD

This design manual is one of a series developed from an evaluation of facilities in the shore establishment, from surveys of the availability of new materials and construction methods, and from selection of the best design practices of the Naval Facilities Engineering Command, other Government agencies, and the private sector. This manual uses, to the maximum extent feasible, national professional society, association, and Institute standards in accordance with NAVFACENGCOM policy. Deviations from these criteria should not be made without prior approval of NAVFACENGCOM Headquarters (Code 04).

Design cannot remain static any more than can the naval functions it serves or the technologies it uses. Accordingly, recommendations for Improvement are encouraged from within the Navy and from the private sector and should be furnished to NAVFACENGCOM Headquarters, Code 04. As the design manuals are revised, they are being restructured. A chapter or a combination of chapters will be issued as a separate design manual for ready reference to specific criteria.

This publication is certified as an official publication of the Naval Facilities Engineering Command and has been reviewed and approved in accordance with SECNAVINST 5600.16.

J. P. JONES, JR.
Rear Admiral, CEC, U. S. Navy
Commander

COMMUNITY FACILITIES DESIGN MANUALS

DM Number	Chapter superseded in Basic DM	Title	Date Issued
DM-37.01	2, Sec. 10, 11	Swimming Pools	3/85
DM-37.02	---	Child Care Centers	---
DM-37.03	3	Outdoor Sports Facilities	8/76
DM-37.04	1, Sec. 2	Brigs and Detention Facilities	1/85
DM-37.05	---	Family Service Centers	----
DM-37.06	2, Sec. 2	Chapels and Religious Education Facilities	9/85
DM-37.07	2, Sec. 5	Clubs	----

CHAPELS AND RELIGIOUS EDUCATIONAL FACILITIES

CONTENTS

	Page
Section 1. INTENTIONS AND PROCESSES OF DESIGN	37.06-1
1. SCOPE.....	37.06-1
2. CANCELLATION.....	37.06-1
3. COORDINATION.....	37.06-1
4. RELATED CRITERIA.....	37.06-1
a. Department of Defense Manual.....	37.06-1
b. Criteria Sources.....	37.06-1
5. PROGRAMMATIC GOALS.....	37.06-2
a. The Command Religious Program.....	37.06-2
b. The Necessary Shelter.....	37.06-2
c. Typical Schedules of Use.....	37.06-3
6. SPECIAL ASPECTS OF NAVAL FACILITIES.....	37.06-3
a. Authorities in control.....	37.06-3
b. Interfaith Function.....	37.06-3
c. The Bases of Religious Architecture.....	37.06-4
d. Variable Uses of Spaces Planned for Worship.....	37.06-5
e. Consultants in Liturgical Arts.....	37.06-5
Section 2. PLANNING FACTORS	37.06-6
1. THE SITE.....	37.06-6
a. Importance.....	37.06-6
b. Criteria.....	37.06-6
c. The Ideal Site.....	37.06-7
2. TYPICAL FACILITIES EXEMPLIFIED IN PLANS.....	37.06-7
a. The Examples in This Manual.....	37.06-7
b. Area Assignments.....	37.06-7
3. SPACE RELATIONSHIPS.....	37.06-7
a. Space Adjacencies.....	37.06-7
b. Further Comments on Flexible Use.....	37.06-8
c. Entrances.....	37.06-9
d. Control.....	37.06-9
4. CODES.....	37.06-9
a. Life Safety.....	37.06-9
b. Provision for the Handicapped.....	37.06-9

CONTENTS

	Page
5. SPACE ALLOCATIONS STANDARDS.....	37.06-9
a. Overall Programming.....	37.06-9
b. Standards for Special Use Spaces.....	37.06-9
c. Typical Space Allocations.....	37.06-11
6. HOSPITAL CHAPELS.....	37.06-11
a. Size and Use.....	37.06-11
b. Character.....	37.06-12
c. Location.....	37.06-12
d. Furnishings and Equipment.....	37.06-12
Section 3. GENERAL DESIGN FACTORS.....	37.06-13
1. EXTERIOR FACTORS.....	37.06-13
a. Contextuality.....	37.06-13
b. Distinction.....	37.06-13
2. THE MAJOR ASSEMBLY SPACE.....	37.06-13
a. Entrance and Exit.....	37.06-13
b. The Shape.....	37.06-13
c. Balconies.....	37.06-13
d. Ambience.....	37.06-14
e. Seating.....	37.06-14
f. Provisions for Music.....	37.06-14
g. Platform.....	37.06-15
h. Liturgical Furniture for Christian Usage.....	37.06-15
i. Jewish Usage.....	37.06-18
j. Islamic Worship.....	37.06-18
3. SECONDARY WORSHIP SPACES.....	37.06-19
a. Multi-Purpose Chapel.....	37.06-19
b. Chapel of Reservation.....	37.06-20
c. Reconciliation Rooms.....	37.06-20
4. SPACES ANCILLARY TO WORSHIP.....	37.06-21
a. The Concourse.....	37.06-21
b. Sacristy and Vestry.....	37.06-21
c. Liturgical Storage.....	37.06-22
d. Music and Choir Room.....	37.06-22
e. Other Ancillaries.....	37.06-22
5. PROVISIONS FOR ADMINISTRATION AND STAFF.....	37.06-23
a. Accessibility.....	37.06-23
b. Staff Offices.....	37.06-23
c. Chaplains' Offices.....	37.06-23

CONTENTS

	Page
6. SPACE FOR SOCIAL ACTIVITIES.....	37.06-24
a. The Social Hall.....	37.06-24
b. Attendant Spaces.....	37.06-25
7. RELIGIOUS EDUCATIONAL SPACES.....	37.06-25
a. Scope.....	37.06-25
b. Infants and Children of 2 and 3 years of Age.....	37.06-26
c. Small Children	37.06-26
d. Juniors through Adults.....	37.06-26
e. Management Spaces.....	37.06-27
Section 4. SPECIAL DESIGN FACTORS.....	37.06-28
1. ACOUSTIC QUALITIES.....	37.06-28
a. General Comments.....	37.06-28
b. Room Acoustics.....	37.06-28
c. Isolation of Sound.....	37.06-28
2. COMMUNICATIONS.....	37.06-29
a. Telephone and Intercoms.....	37.06-29
b. Speech Reinforcement.....	37.06-29
c. Visual Aids.....	37.06-29
3. LIGHTING.....	37.06-30
a. Natural Lighting.....	37.06-30
b. Artificial Lighting.....	37.06-31
4. MECHANICAL SYSTEMS.....	37.06-32
a. HVAC.....	37.06-32
b. Plumbing.....	37.06-32
5. FURNISHINGS AND EQUIPMENT.....	37.06-33
a. General Notes on Procurement.....	37.06-33
b. Groups of Furnishings and Equipment.....	37.06-33
6. SYMBOLS AND ARTIFACTS.....	37.06-37
a. Crosses.....	37.06-37
b. Jewish Symbols.....	37.06-38
c. Islamic Devices.....	37.06-38
d. Stations of the Cross.....	37.06-38
e. The Tabernacle.....	37.06-39
f. Candlesticks.....	37.06-39
g. Fabrics.....	37.06-40
h. Special Works of Art.....	37.06-40

TABLES

Table	Title	Page
1	Factors Useful to Determine Areas.....	37.06-10
2	Area Allocations of Sample Chapels and Religious Educational Facilities.....	37.06-11
3	Typical Utility Requirements.....	37.06-95

FACILITY PLATES

Sheet Number	Title	Page
1	Plan Studies 100 Seat Chapel with Related Religious Educational Facilities.....	37.06-41
2	Developed Plan for 100 Seat Chapel and Related Religious Educational Facilities.....	37.06-43
3	Various Configurations for a 100 Seat Chapel.....	37.06-45
4	Plan Studies for 300 Seat Chapel with Related Religious Educational Facilities.....	37.06-47
5	Developed Plan for 300 Seat Chapel and Related Religious Educational Facilities.....	37.06-49
6	Various Configurations for a 300 Seat Chapel.....	37.06-51
7	Plan Study for a Chapel Seating 500, a Second Chapel Seating 75 and Related Religious Educational Facilities.....	37.06-53
8	Plan Study for a Chapel Seating 500 with Related Religious Educational Facilities.....	37.06-55
9	Developed Plan for 500 Seat Chapel With Related Religious Educational Facilities.....	37.06-57

CONTENTS

Sheet Number	Title	Page
10	Configuration for a Chapel with an Internal Subdivision Seating 425 and 75 in Its Parts.....	37.06-59
11	Configuration for a Chapel with an Internal Subdivision Seating 425 and 75 in Its Parts.....	37.06-61
12	Configuration for a Chapel with an Internal Subdivision Seating 425 and 75 in Its Parts.....	37.06-63
13	Plan Study for an Unattached Religious Educational Facility of 10,000 Square Feet.....	37.06-65
14	Developed Plan for an Unattached Religious Educational Facility.....	37.06-67
15	Typical Wood Platform Module.....	37.06-69
16	Altar Table/Bimah.....	37.06-71
17	Ark.....	37.06-73
18	Portable Screen for Reconciliation Rites with Kneeler.....	37.06-75
19	Typical Scheme for Sacristy and Vestry.....	37.06-77
20	Typical Baptismal Vessel.....	37.06-79
21	Processional Cross.....	37.06-81
22	Processional Cross.....	37.06-83
23	Menorah.....	37.06-85
24	Typical Tabernacle with Pedestal and Lamp.....	37.06-87
25	Portable Floor Standing Candlesticks.....	37.06-89
26	Pascal Candlestick.....	37.06-91
27	Tract Rack.....	37.06-93

CONTENTS

	Page
References	Reference-1
Index	Index-1

Section 1. INTENTIONS AND PROCESSES OF DESIGN

1. SCOPE. This document deals with the information and procedures which architects and engineers need to use in the design of chapels and religious educational facilities for the naval services.

2. CANCELLATION. This manual on the design of chapels and religious educational facilities, NAVFAC DM-37.06, cancels and supercedes Section 2. CHAPELS, of Chapter Two, NAVFAC DM-37 Community Facilities of March 1975, including Change 1 of June 1976.

3. COORDINATION. Policies, obligations, and responsibilities of other commands and/or offices are referred to only as they affect the Naval Facilities Engineering Command (NAVFAC) projects.

4. RELATED CRITERIA. Requirements of the Department of Defense (DOD) shall be fulfilled.

a. Department of Defense Manual. Comply with the latest Department of Defense Construction Criteria Manual. DOD 4270.1-M, for space criteria, construction, finishes, fire protection, plumbing (including required fixtures), heating, ventilating, air conditioning, environmental control, compressed air and vacuum systems, elevators, and architectural and electrical designs.

b. Criteria Sources. For criteria related to the design of chapels and religious educational facilities but appearing elsewhere in the Design Manual series, see the following sources:

Subject	Source
Architecture	NAVFAC DM-1 series
Structural Engineering	NAVFAC DM-2 series
Mechanical Engineering	NAVFAC DM-3 series
Electrical Engineering	NAVFAC DM-4 series
Fire Protection Engineering	NAVFAC DM-8
Interior Design	NAVFAC DM-14 series

All publications cited in this manual form a part of it to the extent they are referenced and contain criteria related to the subject matter of this manual.

5. PROGRAMMATIC GOALS.

a. The Command Religious Program The intentions of the religious program in the Navy are broad. The most explicit of them are to provide for the free exercise of worship among personnel of all faith groups, to offer religious education and personal counselling in religious matters, and to undertake the general enhancement of spiritual values among Navy personnel.

In addition, there may be offered, within the facilities of the religious program, human services of various kinds to groups and individuals. All these, having their basis in the free exercise of religion, contribute to the building of community identity and cohesion, and to the assertion, overt or implied, of human relatedness under God.

b. The Necessary Shelter. To support the varied activities, structures are supplied having some spaces of specific function and others of flexible uses.

Corporate worship and private devotional experience are supported by the provision of worship space for all religious communities. Leadership may rest with Navy chaplains, with nonmilitary clergy, or with nonprofessionals. Ritual events, such as baptisms, weddings, funerals, bar mitzvahs, memorial services and various commemorations are also accommodated.

Religious education for service personnel, their families and other personnel associated with military bases may include persons from 3 years of age through adulthood. Such programs are intended to serve all faith groups; they are led by professional Navy personnel, by civilians under contract, and by volunteers. They may be very extensive on larger naval or Marine Corps bases, and may require a large amount of area of varied types. Religious counselling for individuals or groups occupies consequential amounts of the chaplains' time.

Fellowship and social activities need to be accommodated. Times of social encounter may precede and follow worship times or other ritual events and may be accompanied by food and drink. Other events--may be planned also where refreshments and light meals are appropriate.

The facilities are commonly only open to many nonsectarian assemblies and activities. Among them may be on the one hand, nonreligious educational training and testing programs; on the other, musical or theatrical events, dances, cinema, lectures, and discussions. And the facility may supply shelter for clubs, youth groups, women's groups, the Red Cross, Alcoholics Anonymous, and so forth.

In some instances these facilities have been used by departments other than the religious program for child care and preschool activities. When such circumstances are present, special attention is needed in allocation and control of spaces.

c. Typical Schedules of Use. Chapel facilities are normally open and staffed daily from 8:00 A.M. to 8:00 P.M., but late evening activity is frequent also. Worship events follow as much as possible customary times; religious education may be limited to Sunday, but may also occur on weekdays. Other activities are scheduled appropriately.

6. SPECIAL ASPECTS OF NAVAL FACILITIES

a. Authorities in Control. Naval chapels differ from comparable facilities in civilian situations in a number of very significant ways. The most obvious of these is that although they are intended for religious purposes they are owned and operated by a secular institution, the Navy. The commanding officer of the base is the final authority on their function and use.

The Commander of the Naval Facilities Engineering Command (NAVFAC-ENGCOC) is responsible for the procurement of chapels and religious educational facilities. In the planning and design process the officials of the base and personnel from the Chief of Chaplains' Office participate through the appropriate Engineering Field Division of NAVFACENGCOC.

b. Interfaith Function. A major difference between military and civilian facilities is that the former are nonsectarian and are designed to meet the needs of all military personnel and all faith groups within the same premises. The liturgical and theological understanding that is permanently reflected or given an image in these facilities must be that which is held in common by all religions. The implications of this for architecture are several:

Architectural symbols, shapes, or configurations that are denominational or sectarian in character or association should not appear as exterior motifs. Neither should they be permanent elements of the interior within the spaces that are shared by the various faith groups. An exterior example is the spire; interior examples would include details suggestive of the Trinity, the Star of David, the cross, etc. Such symbolic devices may be appropriately among the portable and impermanent furnishings, but must not be fixed.

The facilities must, nevertheless, be thoroughly hospitable to the uses of various religious denominations. Furnishings, equipment, artifacts and symbolic devices appropriate to the various denominational patterns of worship are to be provided so that the sense of "church",

"synagogue", or "meeting house" is vividly present. Success in this intention inevitably depends on radical adaptability in which the configuration of the furnishings, and even such things as platforms, can be changed to suit various occasions. And a full supply of furnishings, equipment, artifacts and symbolic devices appropriate to various religious denominations must be provided so that there is a minimum sense of the provisional and ad hoc.

Although historical architecture often suggests the opposite, theologians of almost every faith agree that "ecclesiastical" or other "religious" styles of architecture are neither necessary nor advantageous. A "secular" style of architecture is appropriate; but it must be noted that "secular" in this usage is not the opposite of "sacred", nor does it mean commonplace or run-of-the-mill; it simply means nonecclesiastical.

c. The Bases of Religious Architecture. To say that naval chapels must not be ecclesiastical or sectarian in style and detail does not mean that these buildings cannot be expressive of religion; indeed, they must be. Designers must attempt conscientiously to provide buildings that are faithful and vivid reflections of those elemental properties of religion that are common to all faiths. There are three of these fundamental properties of religion, all of which are expressible in architecture without recourse to sectarian forms, symbolism, or images.

(1) In the first place, religion is a commitment to the faith that human life and the universe have their being under an ineffable, fascinating, and awesome Mystery we call God and call Holy. This is the common intuition of all religions. The Mystery is infinite, eternal, transcendent, yet immanent. Humans experience in an immense variety of ways that the beauty of the natural world is evidence of the Magnificent Mystery; these experiences are felt rather than cognitive, intuitive rather than rational, and they bring people to awe and wonder.

The only adequate means available to people of symbolizing the Holy is through their own works of beauty. The reason is that beauty is also a mystery; it also awakes in people a sense of wonder. Beauty, like the holy, cannot ultimately be defined, analyzed or synthesized. Like the holy it is both remote and immediate; it is perceived by intuition rather than by cognition. And beauty, as a lesser mystery invites the awareness of the Greater Mystery. This is the reason that in every religion the artist and the priest have been hand in hand.

It is of the greatest importance, therefore, that the architecture of religious facilities be beautiful.

(2) Religion, in the second place, is the devotion to truth,

reality, authenticity, and integrity. Architecture which seeks to reflect this aspect of religion avoids illusion, deceit, dissimulation, artificiality, artifice, and cosmetics. It is what it appears to be. It is coherent, candid, authentic, whole.

(3) Finally, religion is committed to ethical postures; it seeks the good; and it supports the welfare of persons and society. Architecture that echoes this property is hospitable; humane, generous, noble, lively. It has the qualities that we find in the people we call "good". It is not authoritarian or pompous; it does not aim to impress or overwhelm, but to be a good servant, a gracious host and warm companion.

d. Variable Uses of Spaces Planned for Worship.. Although the primary use of the chapel-assembly paces is for common worship these spaces are available also for other appropriate community assemblies when schedules permit. Their flexibility and "secularity" may encourage this, and certain elements of furnishings and equipment may also be variously usable.

Nevertheless, certain spaces are assigned to meet the particular needs of particular faith groups, and are not to be understood as available for other purposes. Examples are the Chapels of Reservation provided for Roman Catholics and the facilities provided for kosher food service. Obviously a great many of the articles of equipment and furnishings may also be restricted in their use.

e. Consultants in Liturgical Arts. Those Architectural/Engineering (A/E) firms who have little experience in the design of places of worship, or whose experience is limited in denominational variety, or has not been based on the concepts of adaptability and secularity necessary for naval facilities, should obtain the help of a consultant, to serve as instructor, critic, and aide. The use of liturgical consultants is encouraged and consistent with Chief of Naval operations Instruction (OPNAVINST) 5430.48. The Contracting Officer may require the services of a consultant in the Scope of Work of the Contract of the Architect/Engineer. The applicable sentences of the OPNAVINST reads as follows:

"...The liturgical and acoustical requirements of religious facilities as well as any other specialized requirements of these facilities due to their unique use shall be carefully evaluated and documented during the design process."

Consultants, when used, shall be active from the very beginning of the A/E work until design detail is complete.

Section 2. PLANNING FACTORS

1. THE SITE.

a. Importance. Activities sheltered by chapels and religious education facilities are voluntary. Because of this the success of the religious program (which means its capacity to be of service) depends focally on the selection of sites that are advantageous. The siting of chapels on military bases is no less critical than the siting of commercial enterprises in civilian situations.

b. Criteria. A series of factors must be evaluated.

(1) Accessibility. Chapels need to be accessible to personnel who are pedestrians as well as to those who can travel by auto or bus. Proximity to barracks is important to serve the former; the distance traversed by people who drive is not critical once they are in their vehicles. If bus routes exist they should be considered.

(2) Visibility. Sites on well-traveled routes, where the structures are easily and often seen, are to be favored.

(3) Appropriate Adjacencies. Neighboring structures or facilities should be related in scale and architecturally compatible if possible. Sufficient space for appropriate landscaping is desirable. The Base Exterior Architectural Plan, if available, is to be consulted and respected.

(4) Utilities and Services. For the sake of economy the sewer, water, electric, and steam (where applicable) services should be readily available.

(5) Acoustic Environment. Aircraft flight paths or proximity to noisy athletic fields or other noise generating activities should be avoided.

(6) Parking. As with commercial ventures the nearby availability of adequate parking is of paramount concern. This may be on the site, supplied as part of the project, or it may be space shared by other facilities. The standard of adequate parking is high because of the typically tight schedule of Sunday morning activities, when one group of worshipers may arrive before an earlier group has left. Such standards, which normally range between three and five seating places in a place of worship for each parking space, must be evaluated against the expectations of personnel arriving by car or by foot and public transportation. Reserved parking for staff members and proper access to service entrances should be planned.

c. The Ideal Site. An ideal site might be a block or two inside the main gate on the principal street, with a generous landscaped margin, adjacent to the parking area furnished for the Base Exchange (so that parking space can be shared), and within easy walking distance from the enlisted personnel quarters.

2. TYPICAL FACILITIES EXEMPLIFIED IN PLANS.

a. The Examples in This Manual. No series of precise programs can be supplied to match the varied needs of military bases. This manual deals with four selected situations. The examples are as follows:

(1) A chapel seating 100 plus a religious educational facility of 3,855 square feet (358 m²). Facility Plates 1-3, pages 37.06-41 through 37.06-45.

(2) A chapel seating 300 plus a religious educational facility of 5,000 square feet (465 m²). Facility Plates 4-6, pages 37.06-47 through 37.06-51.

(3) A chapel seating 500 plus a religious educational facility of 7,500 square feet (697 m²). A variation divides the seating into two spaces seating 425 and 75 respectively. Facility Plates 7-12, pages 37.06-53 through 37.06-63.

(4) A religious educational facility, sited alone, of 10,000 square feet (930 m²). Facility Plates 13 and 14, pages 37.06-65 and 37.06-67.

b. Area Assignments. The areas approximated on the plans in this manual are derived from Facilities Planning Factors Criteria for Navy and Marine Corps. See each project to determine any variations from the tables. Space for mechanical equipment will vary according to local situations. In planning a facility it is acceptable to consider the area allowances for worship and religious education respectively as a total sum, to be allocated in proportions that meet the local need.

3. SPACE RELATIONSHIPS.

a. Space Adjacencies. Although these facilities are titled under two headings, "Chapels and Religious Educational Facilities", they are normally designed as one complex and the functions can conveniently be subdivided into five groupings which overlap and interact.

(1) Worship Spaces and Their Ancillaries. This group includes the major and minor assembly spaces used for worship, baptistry, sacristy, vestry, choir and music room, chapel of reservation, reconciliation room(s), concourse, storage space for liturgical furnishings, and any other supporting spaces.

(2) Social Area and Its Ancillaries. This group includes the fellowship space, kitchen, storage, outdoor patio, lanai or court used for informal gatherings, and service access; it is desirable that the concourse mentioned in (1) above should serve this group also.

(3) Administrative Spaces. This group includes chaplain's office(s) and staff space(s), reception space, and storage. Access may be from the concourse, but in large facilities a separate weekday access may be appropriate.

(4) Religious Education and Multi-Purpose Spaces. This group includes rooms for teaching, conferences, meetings of various types, recreational and self-improvement activities, storage spaces and play yards. The social space noted in (2) above is available for religious education activity. Secondary entrances may give access. The office for staff responsible for religious education may be located in this group.

(5) Service and Utility Spaces. Toilets, mechanical rooms, custodial rooms, and building storage are deployed for convenience. Because mechanical maintenance and site maintenance is furnished by personnel of the Public Works Office major mechanical rooms should be accessible without entering the building.

b. Further Comments on Flexible Use. As much as possible, spaces should be planned to serve a variety of functions. Because the capacity of worship spaces cannot be planned to accommodate attendance on festival days, the concourse or the social hall should be so related to the major worship space that overflow seating can be supplied. Movable partitions can be provided. As a less desirable solution, sound and video can be piped into overflow areas.

Secondary worship spaces may serve as places for private devotional exercises. Libraries may be conference and teaching rooms. The concourse may, if properly planned, serve as a social hall; it may also serve as reception or waiting space, or as a "cry room". A classroom may serve as music or choir room or as a bride's room. Even a kitchen may serve for teaching. Restrooms may also be dressing rooms for baptismal candidates (and need to be so designed). A storage room may sometimes function as a projection room for a direct or a rear screen system.

c. Entrances. A major entrance, easily identifiable and leading to a concourse is required. It should be located so as to be convenient to pedestrian arrivals and also to those who arrive by car and walk from parking areas; those who come by car should not have to enter by a "back door". A driveway to this entrance is appropriate in large facilities.

In large facilities a secondary entrance leading to the administrative area and to spaces used for weekday activities should be easily visible. Service entrances should not be prominent nor be near to principal entrances. Provide emergency exits as required.

d. Control. Because full staff is not present after working hours, elements of the facility that are not open for use should be subject to locking off. The elements that are conventionally available after working hours are: the devotional chapel, the social hall, meeting and activity rooms, toilets and staff control points.

4. CODES.

a. Life Safety. The life safety provisions of NFPA 101, Life Safety Code, must be followed. See NAVFAC DM-8, Fire Protection Manual.

b. Provisions for the Handicapped. Although active Navy personnel may be presumed to be without physical handicaps, these facilities also serve their dependents and others who may be handicapped. Use Department of Defense Construction Criteria Manual, DOD 4270.1-M, Chapter 18.

5. SPACE ALLOCATIONS STANDARDS.

a. Overall Programming. NAVFAC P-80 provides general standards, but does not deal in special problems nor fix such details as the number of chaplains to be assigned and other data that affect space needs. The program statement for each facility is assembled by the staffs of the Chief of Chaplains and converted into a scope of work by the Naval Facilities Engineering Command.

b. Standards for Special Use Spaces. Following, in Table 1, are special standards applicable.

TABLE 1
Factors Useful to Determine Areas

Space	Factor
Worship spaces of 100 or more seats, including internal circulation and liturgical centers: (Larger assembly places use lower figures)	11-14 sq.ft./seat, (1.0-1.3 m ²) net
Worship spaces of 75 or fewer seats, including internal circulation and liturgical centers: (Larger assembly places use lower figures)	18-25 sq.ft./seat, (1.65-2.3 m ²) net
Chapels of reservation including 6 to 8 kneelers:	200 sq.ft. (18.5 m ²) net
Reconciliation Rooms	60 sq.ft. (5.5 m ²) net
Sacristies	150-200 sq.ft. (14-18 m ²) net
Vestries	100-150 sq.ft. (9.3-14 m ²) net
Liturgical storage and work rooms	150-200 sq.ft. (14-18 m ²) net
Teacher rooms:	
3-5 year olds:	35 sq.ft. per person (3.25 m ²) net
6-11 year olds:	25-30 sq.ft. per person (2.3-2.8 m ²) net
12 and over:	15-18 sq.ft. per person (1.4-1.7 m ²) net
Choir and music rooms:	500 sq.ft. (46 m ²) min.
Size will depend on whether the room is to be used for rehearsal, storage for vestments and instruments, the music program, etc.	
Social halls:	
Major place of worship.	
Smaller chapels	0.60 x area of worship space
Larger chapels	0.50 x area of worship space
Concourses:	0.25 x area of worship space
When these are single-use space.	

Other space allocations not covered specifically in NAVFAC P-80 will follow conventional standards, applicable codes, customary usage, and the particularities of needs identified for each facility.

c. Typical Space Allocations. Table 2 identifies space allocations for two facilities shown in Facility Plates 2 and 5, pages 37.06-43 and 37.06-49. The first is a small unit with one chaplain assigned and normal chapel capacity of 100. The second assumes three chaplains and has a principal place of worship seating 300. NAVFAC P-80 allots 13,245 square feet (1230 m²) plus mechanical space to the latter facility. It should be noted that because much of the space is multi-purpose the space actually available for teaching is higher than the table indicates.

TABLE 2
Area Allocations of Sample Chapels and
Religious Educational Facilities

Space Name	Facility #1		Facility #2	
	Sq.Ft.	m ²	Sq.Ft.	m ²
Principal chapel	1,200	112	3,600	334
Storage related	140	13	200	19
Secondary chapel			700	65
Storage related			50	5
Chapel of reservation	100	9	150	14
Sacristy and vestry	230	21	430	40
Reconciliation room			80	7
Concourse	580	54	1,000	93
Social hall	800	74	2,000	186
Storage related	160	15	250	23
Kitchen	370	34	400	37
Music Room			500	47
Command Chaplain's study	250	23	210	20
Chaplains' studies (2)			370	34
Staff office space	270	25	410	38
Classroom and multi-purpose	1,430	133	900	84
Corridors, toilets, service and other unassignable areas	1,500	139	2,000	186
Total (excluding mechanical room)	7,000	650	13,245	1231

6. HOSPITAL CHAPELS.

a. Size and Use. NAVFAC P-80 prescribes the authorized size for most hospital chapels. However, certain situations, such as regional medical centers, are exceptions.

Hospital chapels are available for use by patients, staff and visitors as places of prayer and meditation. In larger installations they may also be used for the conduct of liturgies and devotional services. In these circumstances the necessary liturgical furnishings and artifacts are provided together with appropriate storage for them.

b. Character. A nonsectarian ambience is required and at the same time the architectural qualities which imply a religious intention (see supra Section 1, paragraph 6c). Light, color, and more than conventional vertical space are useful resources. There are several nonsectarian symbols that may be useful as devices to recall the spiritual quality of life. Among them are moving water, flame, birds, flowers and other growing things, and certain works of art. Symbolic images like the burning bush and quotations from the Hebrew scriptures such as the 23rd Psalm recall to Christians, Jews and (excluding images) Moslems the presence of the divine, but are less meaningful to people of the far eastern religions.

c. Location. Preferred locations are those readily accessible to patients, and at high traffic locations. Sound control is to be considered, as well as visual privacy.

d. Furnishings and Equipment. General seating should be in movable upholstered arm chairs with about 15 percent of the seating supplied in space for wheelchairs and gurneys. Liturgical furnishings shall be portable and minimal. No platform is needed. The altar/table as small as 36 inches (900 mm) square) and a small pulpit are supplemented by a credence. Focal symbols may be limited to a processional cross and menorah. A piano is sufficient but a small self-contained electronic organ is possible. Provision shall be made for devotional literature of various types. A sign board for identifying the chapel and for announcement of service times is required.

An electronic speaker within these small rooms should not be necessary; however, an electronic sound and video system is necessary so that the sound may be enhanced for the hard-of-hearing. and so that the events of worship can be transmitted to bedside television sets.

Section 3. GENERAL DESIGN FACTORS

1. EXTERIOR FACTORS.

a. Contextuality. In conformity with the guidelines of NAVFAC DM-1 Architecture, the general character of these facilities should be contextual. The structure itself and the spaces surrounding it should enhance the overall coherence of the total environment. Use of materials in harmony with, rather than in contrast to, those of neighboring structures is recommended. Landscape elements should provide transition rather than isolation.

b. Distinction. Some distinctive and memorable former m, preferably derived from the interior spaces, is desirable to supply an identity to the facility. A tower (but no steeple), a sculpture, or other external motif may be considered. A scale and exterior detail that conforms to habitational rather than industrial buildings is appropriate. Landscaping elements are to support the sense of openness and invitation, and may contribute to usable outdoor space. The sense of permanence is desired.

2. THE MAJOR ASSEMBLY SPACE.

a. Entrance and Exit. Access should be from the concourse at a single portal or group of doors. To conform with NFPA 101, and also so that the room may be rapidly cleared at tight Sunday morning schedules, other exits are required.

b. The Shape. The space is a single volume of basically simple geometry. The provision for a separate chancel space, apse, or choir is inappropriate. Proportions must be such as to unify rather than separate people or groups of people, and to allow configurations of seating through which people are much aware of each other, and are given opportunity for interaction. Design features such as dominating axialities, implied focus, hierarchical progressions of space or imperious bisymmetry should be avoided because these features limit flexibility of arrangements and use. Ramped floors are obviously an impediment to flexibility. The visibility that ramped floors provide can be provided by elevated platform or dais; such a podium may be built from movable elements and thus maintain radical flexibility in the space. Ramped access to the platform must be possible.

c. Balconies. One criterion of the space is that participants in worship should not be more than about 65 feet (19500 m^{L2J}) from the liturgical centers. When such distances are exceeded because of the large numbers of the assembly, galleries or balconies for seating may be required. The limit of capacity on a single level under this criterion is about 700 to 800 seats. Galleries are usually uneconomical

otherwise and have the further fault of dividing the assembly into two or more parts. When galleries must be supplied, access to them should be from within the principal space.

d. *Ambience.* The chapel room is not a shrine, implying a divine presence associated with a material object. It is not a "House of God" a place separated in character from the "real world" because of the divine presence. It is rather to be seen as a "house of God's people". asserting that the encounter with God is in the real world, and that God's presence is associated with the presence of God's people rather than the presence of a thing.

The implications of this distinction run in two directions. First, the chapel should be earthy, real and secular, associating itself with this world and this age. Second, because the concept of people as mediators of the divine presence gives them immeasurable worth, the place of assembly should be gracious, hospitable, dignified, and noble.

e. *Seating.* In planning the seating for worship spaces, a module of 20 inches (500 mm), shoulder to shoulder, and 36 inches (900 mm), back to back, is proper. Row lengths and aisle widths must follow requirements of NFPA 101. The configuration of seating should avoid characteristic of theater, cinema, or arena. These imply an audience/performer circumstance and are to be avoided because they fail to enhance participatory worship and the sense of community.

Since flexibility is desired, seating may best use the time-honored system of chairs. The chairs should be interlockable, stackable, comfortable, durable, and handsome. Wooden chairs are preferable to metal; fabric upholstery is preferable to plastic surfaces, partly because of its comfort and aesthetic virtue, partly because it best contributes to stable room acoustics. Book racks or boxes, under or between the chairs should be provided. Hassocks or bolsters should be provided for kneeling.

In some instances, such as remodelling, the situation may not allow the full flexibility of chair seating; benches may be used. Heavy, box-type pews should be avoided because they are inconsistent with movable liturgical furniture.

f. *Provisions for Music.* The spaces for choirs and musical instruments must be close together and located with respect to acoustic advantage. A piano is a sufficient instrument in many situations and is considered by many people to be preferable to an electronic organ. Pipe organs may sometimes be possible and need not be elaborate instruments, but electronic organs are a more usual provision. In addition, space must provide for the possible presence of other instrumentalists. Clearly the size and composition of musical groups

vary due to the transience of military personnel and to the variety of worship patterns; therefore provision for these must be flexible.

g. Platform. For the sake of visibility, it is customary that some elements of liturgical activity are elevated. Platforms need not be permanent they can be built-up from movable modular elements and thus maintain the flexibility desired in the facilities. Such modules must not be, nor appear to be, flimsy or trivial, but should be such that they can be moved by one person. 24 by 48 by 6 inches (600 by 1200 by 150 mm) is an acceptable size and 55 pounds (25 kg) a reasonable maximum weight. See Facility Plate 15, page 37.06-69.

The size of the elevated surfaces should be such that the movement required of worship leaders can be done graciously. The appropriate height of the platform will vary according to sight lines. In general, one 6-inch (150 mm) step will be sufficient for up to six rows of distance, two steps for up to ten rows, and three steps for up to thirteen rows.

The first step of a platform is used in some liturgies as a kneeling surface for the reception of the eucharist. A temporary rail and a kneeling cushion may then be attached along the edges of the platform. In naval practice, the railing is not necessarily present. If it is to be supplied, it should be about 28 inches (700 mm) high and should be attached firmly about 10 inches (250 mm) back from the platform edge. This 10 inches (250 mm) is the location for the cushion, which should be about 3 inches (75 mm) thick and filled with dense padding. The rail should be designed in such a way as to suggest a series of prayer desks rather than a fence. If the platform rises more than one step, the second step should be 36 inches (900 mm) back from the first to provide passage for those distributing the eucharistic elements.

h. Liturgical Furniture for Christian Usage. Certain basic items of furniture are required and their sizes and relationships are important in the functional and aesthetic organization of the space. Because they carry symbolic as well as functional burden they must be carefully designed. The designer must not tolerate any artificial materials or veneers; materials, proportions and details should be of superior quality and fabrication flawless. Various denominations will have various patterns of use. The following elements must be accommodated in the planning process, and their shapes considered in the spatial organization.

(1) Altar/table. The altar/table is a table, not a casket or buffet. It may be perceived as a "dining table" for the "family", about which the "family" gathers for the ritual celebratory meal. It stands free in space, accessible not only to the leader of worship but to all the assembly. Because it is a table and not a counter,

because it should be so perceived, and because it should obscure minimally the person who functions behind it, its height should be about 33 inches (825 mm). Ideally the community assembles "around" the table; therefore it should not have a strong frontality. It may be square with a maximum dimension of about 50 inches (1250 mm), or if rectangular its maximum dimension may be about 60 inches (1500 mm) Wood is the appropriate material. See Facility Plate 16, page 37.6-71.

(2) Pulpit. The function of a pulpit is that of a bookstand. However, because it is the place from which Scripture is read and expounded it acquires a symbolic weight which implies an artifact of more substance than a bookstand may seem to need. The bookdesk itself is a surface about 15 by 22 inches (315 mm by 550 sloping at an angle of about 20 degrees, and has a lip at the lower edge. Because people vary in height the height of this surface should be adjustable; the lower edge should be at its lowest about 39 inches (975 mm) above its floor and at its highest about 45 inches (1125 mm). This can be accomplished either by making the reading desk slide up and down or by providing platform units of varying thickness on which the user stands. Because it is important that a preacher's gestures and facial expressions are clearly visible, it is wise, in larger spaces especially, to have the pulpit floor a step above the level of the surface on which the altar/table stands. The pulpit needs to be heavy and large enough to be very stable; but it need not surround the preachers or lectures, nor be a solid wall in front, obscuring them. Its height, except for the bookdesk, should not exceed 36 inches (900 mm). Normally no illuminating device should be attached to the pulpit; however, for certain special occasions, such as tenebrae liturgies that profit from darkness, miniature reading lights are useful. Micro-phones should not be visibly attached to liturgical furniture.

The pulpit is located so that the assembly is essentially in the 180 degrees in front of the speaker, but a field of 210 degrees or more is acceptable if the lateral distances are not great. The pulpit will serve a variety of faith communities including the Islamic.

(3) Lectern. A light lectern is required. This is not something to balance against the pulpit visually. In most liturgies it is a purely functional device to serve nonliturgical purposes or to serve, within the liturgy, those parts of lesser dignity such as giving announcements or leading singing. The lectern is preserved among some Anglicans exclusively for the reading of Scripture, however, and gains symbolic value. The lectern, like the pulpit, profits from adjustability.

(4) Presider's Chair. As is customary in other assemblies the presiding officer in worship is usually given a special chair that

is emblematic of the office. It is not a throne. It may be distinguished from other seating because it has arms, because of its weight or color, or because of a design motif such as an exceptionally tall back.

(5) Credence. One or more small tables are needed. A credence serves as a place for communion vessels and artifacts when they are not on the altar/table. It may serve as an offertory table, or a place for liturgical books. A typical dimension is 30 by 12 by 30 inches (750 by 300 by 750 mm), with an intermediate shelf.

(6) Baptismal Vessels. Baptism, the initiation into Christian commonalities, is a rite of considerable variety. Many Christians practice the baptism of infants, which usually requires no more than a bowl of water and the suffusion of water upon the head of the initiate. Some immerse infants in large vessels of water. Some delay baptism until the age when the initiate makes a personal and conscious decision to accept baptism. Of this latter group some do not immerse, but many do.

The Navy wishes to make all patterns possible. This intention has implications for baptismal vessels, their location, and their accessories.

It can be accomplished most readily by providing two vessels. One is a generous basin, of metal, china or other material which can be set on a stand or on a credence in the place of worship. A pitcher or ewer to bring the water to the basin should also be supplied,

The other is a vessel big enough for immersion of adults. See Facility Plate 20, page 37.06-79. Its location may be just inside the entrance to the place of worship or just outside (if there is room there for people to gather about for the ritual). Such locations make unnecessary the provision for holy water stoups for Roman Catholic worship. It is so shaped that its water level is about 24 inches (600 mm) above the floor. The floor surfaces around should pitch slightly to a drain. There must be convenient provision of dressing rooms for the candidates.

Accessible tanks of water may be hazardous where little children are present unattended. Precautions, such as a decorative and removable grillwork just below water level, should be taken.

The program for each facility will indicate whether or not such a baptismal tank is to be included, and the Preliminary Engineering Documentation prepared pursuant to NAVFACINST 11010.14, "Project Engineering Documentation (PED) for Proposed Military Construction Projects" will record it.

i. Jewish Usage. in chapels where two worship spaces are programmed it is likely that Jewish services will usually take place in the smaller one. However, on the High Holidays the number assembling may require the use of the larger space. The following elements of furniture are to be accommodated:

(1) Ark. The ark is a piece of casework raised on legs or a pedestal to contain the scrolls of the Torah. Its interior dimensions are not less than 12 inches (300 mm) deep, 24 inches (600 mm) wide, and 48 inches (1200 mm) high. Its height may thus be about 7 feet (2100 mm). It has doors on the front. It may rest on casters, but carrying handles making it portable by two persons are appropriate. It is most conveniently made of wood, is carefully designed and fabricated to be the container of a treasure. A veil or curtain that can be drawn aside hangs just inside the doors. This veil should be of fine fabric and the interior of the case richly finished. It may be lighted with interior showcase lamps. A necessary adjunct is the "Eternal Light". This lamp, which may be electric, is mounted so that it is located about one foot (300 mm) in front of and somewhat above the ark. See Facility Plate 17, page 37.06-73.

The Torah scrolls, being calligraphy on parchment or vellum, are very expensive and are not in the possession of most military chapels. Scrolls have sometimes been loaned or donated. Such possibilities may be available through the Commission on Jewish Chaplaincy, National Jewish Welfare Board, 15 East 26th St., New York, NY 10010.

(2) Bimah. The bimah is a reading desk upon which the scrolls of the Hebrew scriptures are laid to be read. The article of furniture described as altar/table may also serve as bimah. It should have placed upon it a sloping surface about 36 inches (900 mm) square in plan, with a lip along the lower edge. On this the Torah scrolls are placed and unrolled. Because the surface of the parchment is not to be touched the lecturer uses a small pointer called a "yad" to keep the place. See Facility Plate 16, page 37.06-71.

(3) Prayer Garments. The custom of wearing a yarmulka (cap) and a tallit (prayer shawl) by the men who attend worship implies a portable storage unit where these garments can be made accessible to those who come, and in which they can be stored away. A bin for yarmulkas together with a rod for draping tallits, mounted on casters is an effective solution.

j. Islamic Worship. A room used for Islamic worship requires no seating, and it must be devoid of representational art.

(1) Pulpit. A pulpit, which in a large room will require an elevated platform, is supplied for the preacher at the Friday worship.

(2) Mihrab. Adjacent to the pulpit is a device which has the function of indicating the geographical direction of Mecca (qiblah) toward which worshipers face. No rigid rule establishes the form of this device; it may be as simple as a banner. But tradition features a mihrab. The mihrab is an arched niche. It need not be permanently anent, but can be carried into a room and set at the appropriate place at the perimeter. The face of the mihrab is perpendicular to the qiblah direction. It may be an ogee arch decorated with geometric designs and devotional inscriptions in arabic. Its size is related to the scale of the space and to the fact of portability. Its surface may be faced with enamel, gold leaf, tiles. or other durable material.

(3) Garments and Fabrics. The custom of removing shoes for worship requires that portable racks for oboes be supplied at the entrance of the room. A supply of skull caps should be available in a portable bin. If the worship is conducted in a room with a hard floor, individual rugs about 30 inches (750 mm) by 6 feet (1800 mm) should be available from a portable storage rack. An alternative is larger rugs or rolls of carpet.

(4) Ablutions. A part of Islamic worship is the ritual washing of mouth, hands and feet which precedes entry into the place of prayer. Where water or ablutionary facilities are not available, ritual gestures replace actual washing. In military chapels it is appropriate to increase beyond normal requirements the number of basins and taps in men's and women's rooms if the program statements include provision for Islamic groups.

3. SECONDARY WORSHIP SPACES.

a. Multi-Purpose Chapel. A secondary place of worship is recommended in chapels where the principal place of worship itself has more than 250 seats.

(1) Size. Its capacity should be 15 to 18 percent of the normal capacity of the major assembly, with a maximum size of 75 seats.

(2) Purposes. Its purpose is to accommodate all faiths in various ways. For Roman Catholics it may be the place of daily mass and possibly of the rite of Penance (but not the place of Reservation). It may be the place of Jewish Sabbath services or Islamic worship. It may be the place of small weddings, funerals or other rituals. It will also serve as the place of private prayer and meditation and possibly as a room for some element of the religious education program.

(3) Location. This chapel should be so located as to be conveniently accessible whenever the facility is open. It should also be convenient to the sacristy and vestry which are ancillary to the major assembly space.

(4) Furnishings. Some OF the furnishings in a room with such a broad range of uses must be easily moved into convenient storage. Seating shall be chairs, and kneeling hassocks or bolsters shall be provided. In chapels seating up to 40 or 50, no platform should be required. Larger capacities will need a one step elevation. Altar/ table, small pulpit, presider's chair, credences, and piano or organ are necessary. For Jewish worship, an ark and bimah are needed. For Islamic worship see the preceding section.

It is appropriate that there be present some nonsectarian and nonrepresentational work of art or symbolic element that may suggest the presence of the divine in the world; stained glass is an example.

b. Chapel of Reservation. To serve the devotional piety of Roman Catholics while preserving the nonsectarian intentions generally, it is appropriate to supply a small chapel for the tabernacle and devotional exercises related to the Reserved Host.

This room should be easily accessible; it must be large enough for the tabernacle with its lamp and for a few prayer desks. The sense of privacy should be present, but natural light is desirable. See Facility Plate 24, page 37.06-87.

c. Reconciliation Rooms. The Roman Catholic Sacrament of Penance involves a conversation between the penitent and a priest in a private place. Typically, penitents enter a room and find a prayer desk and perhaps a seat in front of a visually opaque but aurally transparent screen. Penitents may kneel or sit to make confession to a priest seated behind the screen, and preserve anonymity. Or penitents may walk past the screen to find a chair where they can converse openly with the priest.

Such a room is appropriately close to the Chapel of Reservation, and adjacent to a place where waiting penitents can sit. Ideally, it opens from the secondary worship space as does the Chapel of Reservation. The rite is normally scheduled for only a few hours a week. Besides the prayer desk, screen and chairs,, a small table serves as a place for books. Acoustic privacy is important. A way of signalling that the priest is present is needed; it may be as simple as a lighted candle at the door.

If there is no reconciliation room in the program or when a second one may be desirable, requirements make it possible to turn various rooms into Reconciliation Rooms by supplying portable furniture and proper privacy. See Facility Plate 18, page 37.06-75.

4. SPACES ANCILLARY TO WORSHIP.

a. The Concourse. The concourse should be a generous foyer. It is a place of welcome and should have that hospitable quality. It is a place of encounter and human interaction, and not merely a transitional space. Benches or other seating may appropriately be present. Provision should be made for the display of religious literature and tracts, for bulletin boards or easels, and possibly for art exhibits. See Facility Plate 27, page 37.06-93.

In some climates provision for coat storage is necessary, though separated coat rooms should be avoided because of congestion at their access points. Distributing coat pegs or hooks along walls is usually better. Portable coat racks that can be deployed in bad weather are another solution. Such racks may be stored in an ushers' room contiguous to the concourse if such a space is programmed. Include an usher's room, in any case, room store extra chairs; book carts for supplies of missals and other books or the Book of Worship; and containers for yarmulkas, prayer shawls, skull caps, and shoe racks.

In some building configurations, where movable partitions can be incorporated, the concourse may provide good expansion of the place of worship for festival assemblies.

b. Sacristy and Vestry. A sacristy is a room for the preparation, maintenance and storage of cultic artifacts and materials, and is furnished to serve these purposes. A counter space with a sink similar to those of kitchens has base cabinets below and wall cabinets over. Sacramental vessels, torches, candlesticks, and supplies need storage. Precious vessels and sacramental bread and wines and oils for Christian and Jewish rites must be in locked storage. An undercounter refrigerator (lockable) provides for storage against spoilage of opened wine bottles. Provide drawers for storage for altar and pulpit fabrics and sacramental linens. Ensure space for storage of banners, flower stands, and other decorations. An ironing board and a locker for cleaning equipment is necessary. A sacrarium, which is a small sink with a cover, the drain of which leads directly to the earth, is used for the disposal of sacramental liquids. See Facility Plate 19, page 37.06-77.

The organization of the storage in the sacristy and vestry should be such that articles associated with various denominational groups, where they differ, can be separated and easily identified.

The vestry is so called because it is the place where the clergy clothe themselves in the liturgical vestments and store them. The principal storage is in wardrobes, but there are also drawers for some

articles, a counter, and a full length mirror. Besides the clergy, acolytes or assisting ministers may be vested in this place. Because it is the place where processions begin, it also can be the place for storage of processional emblems, banners or candlesticks, as well as books.

Sacristy and vestry are two rooms except in small chapels. They should interconnect, but each should be accessible directly from circulation routes. Processions enter a place of worship at the main door, so the vestry should be conveniently located. The path from sacristy to the place of worship should be kept short also, but the custom of providing a door directly from sacristy/vestry to the platform or pulpit is not good practice because it has too much the aura of theater.

c. Liturgical Storage. Besides the storage for liturgical artifacts and materials in the sacristy/vestry, another storage space is provided for things that are bulky and for some things that are used rarely. Such a space is indispensable if worship spaces are to be really adaptable. If there are two places of worship, each with its own liturgical furniture and equipment, two store rooms are appropriate.

Items that are to be accommodated include extra chairs, unneeded liturgical furniture, large banners or other symbolic or decorative devices for interior or exterior use, advent wreath, statuary, symbols of the stations of the cross, wedding kneeler, music stands, prayer books for special occasions, seasonal decorations, storage units for yarmulkas and tallits, prayer rugs and skull caps, etc.

This storage space may, in the case of small facilities, be combined with other major storage space. Its location is convenient to the assembly space.

d. Music and Choir Room. In larger facilities a special room designed for rehearsals of choirs and instrumental musicians may be supplied. The room also serves for choir robing and for storage of choir vestments, instruments and music, and as an office for the staff director of music, if there is one. An upright piano, desk and lockable cabinets are provided. The room should have as much volume as can reasonably be provided for the sake of musical resonance: its acoustical quality must be carefully established, free of flutter, dry, and evenly balanced over the frequency range.

e. Other Ancillaries.

(1) Projection Facilities. Provision for film and slide projection needs to be made. In some instances this may imply a room for direct projection, in some a rear screen system. Control of day-

light in the assembly space and a good system of projector controls are important for effective visual aids. Because empty screens are generally disagreeable, rear projection screens should have a method of being veiled when not in use.

(2) Brides' Rooms. These are not programmed as separate spaces, but weddings are frequent in military chapels, so some convenient room should be well equipped with dressing table, mirrors and make-up lighting. A lavatory is appropriate unless a women's room is close by.

(3) Infants' Room. The pattern of building "cry rooms" is being abandoned because it is not consistent with the concept of participatory worship. A better solution is the attended nursery for children under 3, equipped with cribs and the other needs for infant care.

5. PROVISION FOR ADMINISTRATION AND STAFF.

a. Accessibility. The spaces assigned to chaplains and their staff should be so located as to be easily found by visitors. In small facilities this implies a location near the main entrance; in larger facilities a weekday entrance, easily identified, may be appropriate. Visitors should find a receptionist and a waiting space, in character. This waiting space should have a measure of privacy, being separate both from the office where staff are working and from passing traffic.

b. Staff Offices. The work spaces for the enlisted and civilian personnel assigned to the facility are assembled together. Personnel assigned to chapels perform normal clerical duties, but they also work in the religious education program, and supply leadership and administrative services for many other activities. Characteristically they work in an open office arrangement. Exceptions to this are made for directors of music, obviously, and if possible, the leader of the religious education program. Provision for an enclosed workroom where noisy machinery or messy activity may be contained is reasonable in larger facilities. Storage provisions are important but may not require separate rooms.

c. Chaplains' Offices. Access to the chaplains' offices is through the receptionist, which implies contiguity to the staff office space. However, it is desirable that persons who enter or depart the chaplain's offices should be able to do so without passing receptionist and waiting space if they wish.

Chaplains' offices are used for study, for administrative work,

for counselling individuals and couples or sometimes small groups or families, and for some staff meetings. They may also, if required, serve as reconciliation rooms. A narrow sidelight beside the door, or a port in the door itself is required.

The ambience of these facilities needs to be humane, gracious and hospitable. This is not easy in office spaces, but is particularly important in chaplains' offices. Here the typical "business-like" quality of a commercial administrative office is to be avoided. A more domestic quality is supported by the necessity of generous bookshelving; comfortable upholstered seating, carpet or rug and draperies. Such things as fluorescent troffers, gridded acoustic ceilings and bulky desks should be avoided.

6. SPACE FOR SOCIAL ACTIVITIES.

a. The Social Hall. The focus of social activity is a space where food and drink are served, and where informal programs of many kinds may be held. This room should be accessible from the concourse' or, in very large facilities, from a prominent secondary foyer. It should be possible for people to move easily between the major assembly space and the social hall. In most climates it is proper that the social hall open onto an accessible and usable outdoor court, patio, lanai or garden.

The room is radically adaptable and multifunctional. An inevitable function is that of a teaching place and its size will most likely require that it be used by more than one class. Planning must consider several factors. The room must be acoustically very dry, which implies carpet on padding, an acoustical ceiling and sound absorption on vertical surfaces as well. Tables should facilitate small classes. Rolling partitions incorporating blackboards and other teaching aids should be easily moved from storage. If children are taught in these rooms they should be old enough to use full sized chairs.

Food service may range from stand-up receptions to sit-down meals. Round folding tables should be planned, partly because they enhance conversation, partly because they are easily moved.

A variety of assemblies will require facilities for slide and movie projections and wiring for sound. It must be possible to feed sound into this space from the main worship space, and a closed circuit television system should be considered.

An alternate to the electronic connection between this room and the major worship space is a scheme in which the two rooms are contiguous and so related that, if the partition between them, is movable.

the social hall becomes a good extension of the worship space. This requires careful detailing of the movable elements so that they are easy to operate and so that a Sound Transmission Class (STC) of about 45 can be accomplished. Heavy folding walls or horizontally pivoting panels can be used.

b. Attendant Spaces. Two spaces are directly in support of the social hall.

(1) The Kitchen. The size of the kitchen will vary according to the size of the social hall. Its use is for serving refreshments before or after worship services, for receptions following weddings, funerals or other celebrations, for various meetings and community support programs. Full meals are seldom prepared in this kitchen, but covered dish suppers and other food brought from home are often supplied. A commercial kitchen is not a model; equipment will generally be more like domestic appliances, although not without exception. Because many people may be involved in preparing and serving the food, aisles and workspace in the room need to be generous.

Equipment will include range, refrigerator-freezer, dishwasher, garbage grinder, sinks, coffee urns, microwave ovens, ice makers, counters, worktables, cabinets, and a generous series of convenience receptacles at the counters.

The kitchen may also have a separate section for serving kosher foods. The basic principle of such a kitchen is to separate the utensils, containers, and surfaces related to the preparation and serving of dairy foods from those used in meat preparation and service. This separation must not be compromised by those who use the other parts of the kitchen, so special sinks, counters, cabinets and refrigerator/freezers that can be locked off are needed. The PED will indicate the presence of a kosher kitchen in the facility if it is programmed.

The kitchen should be accessible readily from the service entry to the facility, and in large facilities it may be proper to supply a lockable storage room rather than depend on kitchen casework for bulk storage.

(2) Storage. A store room is needed, conveniently related to the social hall for the storage of folding tables and folding or stacking chairs, teaching equipment, lectern, seasonal and occasional decorations, and miscellany.

7. RELIGIOUS EDUCATIONAL SPACES.

a. Scope. The broad range of religious education in a typical

Command Religious Program implies that as much of the facility as possible, excluding only storage and service spaces and the administrative spaces, be conceived as having either a primary or secondary use as classroom space, reflective of religious faith.

b. Infants and Children of 2 and 3 Years of Age. If, in close proximity to the chapel on the military base, there is a child care center, that center shall be used to care for infants and children under 3 while parents are at worship. Otherwise, a nursery is needed. In large facilities this may be a two room unit--a cribroom which is quiet, with rocking chairs and tiered cribs; and a larger interconnecting room where toddlers can play. Sanitary facilities are required. This rather elaborate suite is scaled down in smaller chapels. (In the smallest, the need may not be present. and parents whose infants are disturbing may use the concourse as a "cry room".)

c. Small Children. The typical preschool programs in civilian communities supply models for the rooms and equipment needed for the preschool children. Outdoor play yards are desirable amenities. Separate toilet rooms scaled to small children are appropriate in all but the smallest facilities.

Furniture for children in the lower grades is conveniently small in size, and some teaching equipment is very specialized. For these reasons, rooms for these children are not easily adaptable for other purposes and are perceived as single purpose rooms.

As mentioned earlier, there are circumstances where another responsible group conducts a weekday preschool program in the religious educational facilities. In these situations, it is important that the building be planned to make the double occupancy comfortable and effective. The spaces in question should be grouped together, isolatable from the remainder of the facility and provided with a sheltered weekday access point. Administrative space assignable to the "visiting" group should be supplied in addition to spaces needed by the Command Religious Program. Separate storage, both centrally and within each room, for materials and loose equipment should also be provided.

d. Juniors through Adults. Because flexibility of function is critical in these facilities, rooms allocated to teaching will have other functions also. The alternative uses of the social hall have been mentioned. The music room can serve as a teaching space. Classrooms can serve as reading or study rooms through most of the week.

Game rooms, craft rooms, and places where personnel can rehearse musical or other programs are also available for teaching places.

Since the classrooms are available for other uses and not locked off, it is clear that secure storage for teaching materials must be provided within the rooms. Rooms that are to be used for younger people in the religious educational program are best made subdividable because teaching younger ages is best conducted in small groups. Rollaway dividers that have storage, blackboards, and display surfaces are available commercially or may be custom built.

Even the smallest facility should have at least one classroom that seats thirty adults; it may be subdividable.

e. Management Spaces. An office for a director of the religious education program needs to be provided. In small facilities, this staff person may be located in the administrative suite; in larger ones, there is reason for locating this religious education staff person close to other spaces about which the program functions. These other spaces are a storage and distribution point for supplies and equipment (such as audiovisual aids) and a control point for registering pupils and dealing with teachers.

Section 4. SPECIAL DESIGN FACTORS

1. ACOUSTIC QUALITIES.

a. General Comments. The material in NAVFAC DM-1 is useful, particularly with respect to acoustic isolation. However, there are some issues in chapel design that make the judgment of an acoustic consultant who has experience in places of worship particularly urgent, and the Contracting Officer may require that such a consultant be engaged.

b. Room Acoustics. Large places of worship can be a difficult acoustic problem because they must accommodate to both the reverberation period desirable for speech and that desirable for music; the compromise must be carefully resolved. In addition to the leaders of worship, members of the assembly must be able to hear each other in speech and song, this presents problems very different from those of other auditoriums. The practice of building dry rooms and depending on loudspeakers to distribute sound is not acceptable.

In rooms for assemblies of fewer than 500, it should be possible to avoid the use of public address systems by proper design. This implies sufficient volume overhead, together with proper shapes and surfaces. Overhead surfaces should be generally reflective because absorptive surfaces inhibit musical resonance and distribution. Hard floors are also valuable.

Cushioned seating, because it absorbs sound when vacant and none when a person is present, tends to stabilize the reverberation time in a room, and is therefore commendable.

Air and motor sounds in ventilating systems should be reduced aggressively by duct lining, bends, sound traps and velocity control to a Preferred Noise Criterion (PNC) of 20.

c. Isolation of Sound. Internal isolation problems focus on a few spaces that need particular attention. One group is the rooms that serve for the penitential rites or as counselling rooms, including chaplains' offices, where the sound of conversation must not pass out of the room. Partitions must be full height, sound traps may be required in ductwork, and sound seals at doors. An STC of 50 is satisfactory. Places where musicians rehearse should also be isolated by location or by control devices so as not to be disturbing; an STC of 55 is appropriate. It should be possible, also, to isolate kitchen noises from events in the social hall. A server between kitchen and hall can be most helpful in this matter.

2. COMMUNICATIONS.

a. Telephone and intercoms, Provisions for office telephones and intercom systems are made, and public telephones are located where they are accessible. An intercom system may also connect vestry, choir room, organ bench and an ushers station. This system can be lights rather than sound; its purpose is to coordinate ,liturgical activity. In smaller facilities where distances are short this coordination is not required.

b. Speech Reinforcement. The major assembly space is required to have a high quality public address (P/A) system. Its controls should be near and within the principal entrance. Microphone jacks should be close to all the locations where speech or programmed music can originate (preferably in wall surfaces). Speakers may be a horn cluster or in distributed locations depending on the size and shape of the room. In addition, speakers should be located in the concourse, in the social ball, in the vestry, and in the office area. The latter two locations permit monitoring of services. All these must have individual controls in their spaces. A system for the hard of hearing should be provided. A suitable audio signal should be brought to a place in the office area where it can be directly recorded on a tape deck.

A cordless microphone system is desirable if interference can be confidently avoided; but provisions for a wired system should nevertheless be installed.

Although it is not necessary in secondary chapels that speech be reinforced, it is appropriate that a system be installed that will allow events such as weddings to be recorded.

Some social halls are large enough so that a built-in amplifying system may be appropriate. In smaller ones a movable lectern with its own built-in speaker system is sufficient.

Because films with sound tracks are commonly available for various purposes, wiring to serve this sort of projection is appropriate in the major worship space and in the social hall. This is clearly so in facilities that are large enough to have projection rooms. Interconnection to the general P/A system may sometimes be possible.

c. Visual Aids. In larger hospitals, it is commonplace to broadcast chapel services in closed circuit television systems. Television broadcasts of services from other chapels may sometimes be desired. It is appropriate that provisions for recording programs on videotape--particularly such memorable events as weddings--be facilitated. And in some circumstances, it may be possible to serve overflow groups by video as well as sound.

Videotaped teaching materials are increasingly available. The state of the art in this area of communications should be examined and whatever advantage can be gained, should be. The PED should include data on provisions for video. Film projection should be possible and convenient in the rooms used for teaching, as well as in the major spaces.

3. LIGHTING.

a. Natural Lighting. Lighting in most parts of a facility requires no comment. In respect to the places of worship and prayer, however, certain observations are appropriate. There is no such thing as "religious light" in distinction to "profane light". Good places of worship may be dimly lit like medieval buildings or brightly lit like Christopher Wren's churches. The light may be filtered through colored glass or come through clear glass. Colored glass may supply an exotic character, but other architectural features can counteract this. Clear glass brings a commendable consciousness of the surrounding world, but can be distracting. These things having been said to free designers from the limitations of stereotypes, it is also proper to note that no factor in the design of a place of worship is more important than the nature of its light.

(1) Practical Issues. Practically speaking, glare, which results from the adjacency of a bright source and a dark surface, must be avoided. If sufficient daylight is provided so that artificial lighting is not required during daylight hours, an advantage is gained, but large areas of glass, even when triple glazed, are expensive in terms of the energy used. Backlighting of choir or leaders of worship must be avoided. Skylights can distribute light well and do not leak if carefully detailed.

(2) Colored Glass. The primary virtue of leaded stained glass has always been its color, not its images or symbolic devices. Sectarian symbols and, if Moslems are to use the spaces, any representational art at all must be avoided. Leaded glass should be protected by having a sheet of tempered clear glass outside or, in many circumstances, double glazing. It should be so mounted as to be detachable so the glass can be cleaned occasionally. The use of colored glass need not be limited to the places of worship but colored glass loses vitality in bright interior spaces.

Many people suppose that making stained glass windows is something anyone can do. The assumption is wrong; the technology is not necessarily difficult, but the sensibilities to and knowledge of color and color relationships in a transparent medium are beyond almost all amateurs. Furthermore, amateurs rarely understand the work in relation to architecture, rarely know the range of possibilities in materials,

and can rarely predict and describe their intentions reliably. Good professionals are rare enough; amateurs should be engaged only with great caution.

The use of so-called dalle glass rather than leaded glass may be appropriate in relatively dark surroundings and when the elegance of leading is not beneficial. Many other recent attempts to be inventive in the use of colored glass have brought exotic novelties, but few of them are worth a second venture.

b. Artificial Lighting. Artificial lighting conforms with the directives of NAVFAC DM-4.4, Electrical Utilization Systems, with few but important exceptions, relating especially to the use of incandescent lamping.

(1) Characteristics of Good Lighting. Good lighting requires functional distribution at proper illumination intensities; it implies distribution of light and shade such that spaces and shapes are comprehensible and interesting; it needs some glitter or nonglaring highlights to supply warmth and liveliness; the light must render color as daylight does and it must avoid glare. These qualities are especially important in chapels. The energy conservation of fluorescent and other High Intensity Discharge (HID) sources is to be respected as possible; but that advantage is very moderate in situations where the use of rooms may be only a few hours a week. It may be noted also that although the best fluorescent tubes are of a good color, replacement tubes may vary a great deal.

(2) Lighting Places of Worship. Some events in the assembly spaces will involve considerable reading, some will profit from very low light levels. Therefore the general lighting should be incandescent on dimmers with 30 footcandles top level. Glaring lighting is the enemy of hospitality; therefore the use of high wattage light sources is troublesome even when the source is not directly visible; a larger number of smaller lamps is proper. The use of downlights alone for general illumination is poor practice despite the efficiency measurable in footcandles; shadowed eyes and faces bring a dour and gloomy ambience. The sense of light in a room depends on lighting the surfaces in the visual field (walls rather than floor). Wall brackets, wall washers or other accent lighting are useful.

Along with the general illumination some special spot and flood lighting is needed to focus on liturgical centers. The location and control of special lighting needs critical study, both so that it functions properly and so that variety in configurations of the spaces is supported. The proper angle at which a spot light should light people's faces is about 35 degrees from the horizontal. A higher beam may leave a minister's eyes in shadow; a lower one may give a

disagreeable glare. Pulpits and other foci of action should be lighted from two sources, 60 to 90 degrees apart and of somewhat varied intensity. The use of multi-circuit light-tracks and other devices that provide a very generous flexibility is commended partly because they can provide for theatrical events of some kinds. Dimmers should be supplied; controls should be near the main entrance unless there is a control booth. Location of special lighting instruments should be such that they can be easily and quickly adjusted or changed.

(3) Chaplains' Offices. Incandescent lighting renders color properly, supplies lively highlights and shadows, and conforms comfortably to domestic character. All these qualities support the humane kind of environment that helps chaplains serve personnel that come to them for aid. No ceiling lamps are needed in these rooms; task lighting should be exploited.

(4) Social Halls. As in other rooms where an atmosphere of congeniality and hospitality are premium qualities, incandescent light on a dimmer system is appropriate for social halls. Because the use of these rooms varies, incandescent levels of 20 to 25 footcandles should be supplemented with separately switched fluorescent lamps to bring the levels up to 35 to 40 footcandles.

(5) Exterior Lighting. The evidence of hospitality needs to appear in exterior lighting of the facilities. Provision should be made for lighting special seasonal displays as well as permanent exterior features.

4. MECHANICAL SYSTEMS.

a. HVAC. Requirements for heating, ventilating and cooling conform generally to NAVFAC DM-3.3, Heating, Ventilating, Air Conditioning and Dehumidifying Systems. Comments relating to preventing sound transmission through mechanical systems have been noted in Section 4.1, Acoustical Qualities. See page 37.06-28.

The anticipated operating schedule must be considered in all energy analysis supplied for the design of the project. Separate air conditioning units may be used for areas of diverse occupancy if the study supports this. Energy storage systems may be proposed because of short duration of some loads, and full cooling of all areas may not be effective when considering the energy used.

b. Plumbing. NAVFAC DM-3.1. Plumbing Systems, applies except for three supplementary details:

(1) A Sacrarium. This is a small sink for the disposal of sacramental liquids directly to the ground. The sink needs a cover,

but no trap. A dry well with a very small capacity is sufficient.

(2) Baptismal Water. Where baptism by immersion is programmed, the vessel needs to be supplied with both cold and warm water, and drainage. See Facility Plate 20, page 37.06-79. It must have moving water with the rich symbolism of sufficiency, cleanliness, liveliness and renewal this supplies. Movement and supply must be acoustically acceptable in the multi-use context of the setting. Its plumbing must be so designed that the water can be warmed to 85 degrees F (29 deg. C), that the flow can be fully controlled, and that the water level can be lowered to avoid overflow when immersion is undertaken. Clearly a large volume of water flowing to a drain is an extravagance. Recirculation systems are troublesome and are often noisy as well as costly; they should generally be avoided.

(3) Staff Facilities. In every facility, showers should be available for the use of staff personnel because they may alternate between physical labor and ceremonial participation or encounters with other persons.

5. FURNISHINGS AND EQUIPMENT.

a. General Notes on Procurement. An equipment list is a part of the Project Engineering Documentation. The development and refinement of an equipment list are done in conjunction with the project manager, collateral equipment specialist, and interior design branch, and coordinated with the appropriate personnel from the Chief of Chaplains' staff. To the degree that required furnishing and equipment is available within the Federal supply system, maximum use should be made. Items not available should be identified and specified in accordance with applicable naval practice and the Federal Acquisition Regulation.

b. Groups of Furnishings and Equipment. To ensure a functional chapel there are six groups of furnishings, equipment, artifacts and other items. Every facility will not require all the items in each group.

The naval procurement system separates much equipment into three categories. Category A is equipment furnished and installed by a contractor from Military Construction Program (MCON) funds; this is the second group discussed below. Category B is equipment furnished by the Government from operating funds and installed by the contractor from the Military Construction Appropriation; this category is usually irrelevant to these facilities. Category C is equipment furnished and installed by the Government, usually with operations and Maintenance, Navy (O&MN) funds. This is Collateral Equipment. In the discussion that follows this category is further divided into three groups - the third, fourth, and fifth discussed. In addition to these groups some equipment is consumable and is procured through station funds, the sixth group. But first there is a group of items that does not fit any of the established categories and is described in the following paragraph as Group I.

(1) Group I. Design-Build (Turnkey). Certain specialty items that are not normally within the design expertise of the Architect/ Engineer may be procured under a turnkey contract. Such items would be described as art or as artifact, where the designer is the fabricator and installer, and where competition based on price is impossible or irrational. The contractor may be selected in either of two methods: Advertisement may be made seeking qualified people or firms with whom an agreement can be negotiated (as in the selection of the Architect/ Engineer); or a contractor with particular qualifications may be selected directly. In either instance the appropriate Contracting Officer of the Naval Facilities Engineering Command. and appropriate personnel from the Chief of Chaplains' staff, advised by the Architect/ Engineer, should be involved in the selection of the contractor. The same concern for the quality of art and artifact that is invested in similar civilian facilities is appropriate in naval facilities. Examples of Items in this group are:

- Stained glass
- Pipe organs
- All commissioned artwork and artifacts including statuary, paintings, metalwork, fabrics, glass, ceramics, etc.

(2) Group II. Built in Equipment, (Category A). These items are designed or specified as part of the Architect/Engineer contracts. are funded by MCON and are furnished by the construction contractor. The general rule, stated in NAVFACINST 11010.14. is that any item that is permanently installed or has permanent utility connections may fall in this category. Normally three sources are designated. Sole-source procurement requires authorization. The following items are included in Category A:

- Bulletin boards and signs
- Carillon
- Closed circuit television system
- Fixed screen for direct projection and fixed projectors
- Flood and spot lighting instrument
- Kitchen casework and fixed equipment
- Permanent baptismal vessel
- Permanent bench
- Platform modules
- Public address system. and other built-in communications systems
- Rear projection screen and associated projection equipment
- Sacristy casework and plumbing
- Vestry casework

Wall safe

If the following items are built-in, they are also Category A:

Altar/table
Pulpit
Lectern
Kneeling rail
Pew
Confessional screen
Presider's chair

(3) Group III. Critical Design Factor (Category C). These items of collateral equipment, are distinguished from other items in Category C because they are critically linked to design. Aesthetic coherence, liturgical adaptability and the limitations of things available on the market bring the necessity for careful control of design.

Designers will give them careful design study, providing custom design in harmony with the architectural shelter. Procurement is through bidding by three acceptable sources. A sole source procurement is possible if valid justification based on design requirements is acceptable to the Contracting Officer. Following is a list of items in this group:

Altar/table	Mihrab
Ambry	Missal stand
Ark and associated lamp	Movable confessional screen
Bimah	Movable storage unit for books
Censer stand	Movable storage unit for skull caps, shoes, and prayer rugs
Credence	Movable storage unit for yarmulkas and tallits
Flower stand	Organ case
Hymn board	Portable baptismal vessel and stand
Kneeling desk	Presider's chair
Kneeling hassock or bolster	Pulpit
Kneeling rail	Quran stand
Lectern	Seating
Literature and bookrack for concourse	Tabernacle with associated lamp and mounting features
	Votive stand

In addition the designer may be made responsible for the design of certain artifacts procured as a part of this group. (They may otherwise fall in Group I, above.) They include:

Advent wreath
 Bench for concourse and elsewhere
 Banner
 Candlesticks, processional, floor standing and paschal
 Cross and crucifix
 Liturgical fabrics
 Menorah
 Stations of the cross

(4) Group IV. Important Design Factor (Category C). These items are generally available, and to the degree that suitable items are procurable within the Federal supply system, use shall be made of it. There must be design consideration in the selection and listing because color, texture, style and other practical and aesthetic factors contribute to or diminish those qualities of environment that support the religious program. The following items are included:

Blackboard, portable	Flags and stand
Bookcase	Magazine rack
Bulletin board, portable	Nats, door
Cabinet	Mirror, full length
Chairs	Organ
Clock	Piano
Couch	Picture
Credenza	Planter/plant
Curricula storage	Smoking stand
Desk	Table
Draperies	Wearing apparel rack
File cabinet	

(5) Group V. Routine Selection (Category C). Certain functional items of collateral equipment need to be considered in planning and detailing facilities, but have little or no aesthetic weight and are selected for functional and economic advantage. Their design is not important in their selection. This list may include:

Adding machine	Floor buffer
Carpet cleaning machine	Microwave oven
Cassette recorder, player	Motion picture projector
Coffee maker (20 cup size or larger)	Office machine stand
Copier	Overhead projector
Crib and mattress	Phonograph
Diaper storage chest	Playpen
Easel, flipchart	Projector screen, portable
Equipment stands	Range (except built-in)
Filmstrip projector	Refrigerator, self contained
Fire extinguishers	Safe, portable
	Spirit duplicating machine

Tape recorder	Vacuum cleaner
Telephone tape message device	Word processor
Typewriter	Wastebasket
Typewriter stand	

(6) Group VI. Consumables. Items that are normally worn, read, handled or consumed are funded by the station rather than from MCON or collateral equipment budgets. Some of these items are very significant symbolically and aesthetically and relate closely to items in Groups I and III, above. It is recommended that the selection and procurement of these items be accomplished in consultation with the proper authorities from the Chief of Chaplains' staff and the Naval Facilities Engineering Command and personnel, and, if coordination is possible, with the facility designer.

The following is a list of items which pertain specifically to chapel functions:

Alb	Hosts/Altar bread
Altar bells	Huppah
Amice	Hymnal/book of worship
Baptismal set	Kiddush cup
Bible	Lavabo
Burse	Lay minister's cross and chain
Candles	Lighting taper
Candle lighter	Missal set
Censer and boat	Nativity set
Chalice with patten	Prayer rug
Chalice veil	Purificator
Charcoal	Quran
Chasuble	Rimonim
Ciborium	Scroll of Esther
Cincture	Shofar
Collection baskets/plates	Skull cap
Communion cup	Torah
Communion set, Protestant	Torah breast plate
Communion trays, stacking	Torah cover
Fair linen	Torch crown
Finger purification dish	Tablets of the Law
Frankincense	Tallit
Hadith collection	Wine/grape juice
Holy water pot and sprinkler	Yarmulka
	Yad

6. SYMBOLS AND ARTIFACTS.

a. Crosses. For Christian worship, a central symbol of the cross asserts the presence of the Lord. Because it is not permanently fixed

its size is limited, and its location may be varied. In long axial spaces custom has located the symbol at the remote visual climax; its symbolic meaning is clearer if it is located among the worshipers, on a staff. In smaller chapels a processional cross or crucifix may be the only cross desired. Such a device weighs no more than about 15 pounds (7 kg) and is 80 to 90 inches (2000 to 2250 mm) tall. A base about 30 inches (750 mm) high will lift it sufficiently above the heads of people. In larger spaces other, larger devices may be introduced and they may be on taller staffs or be otherwise displayed. Crosses may be made from a variety of materials including fabrics. Two basic forms with many variations occur. The Latin Cross, with vertical member longer than horizontal is taken as a reference to the death of Jesus and in some traditions the image of the Lord (the corpus) is mounted on it, making what is called a crucifix. The Greek Cross has equal members. It is said to derive from the Greek initial for Christ and has symbolical references to universality, to the meeting of divine and human, and to other things depending on detail. Two processional crosses are needed, one with and one without the corpus.

It is appropriate in a larger space to use both forms, one as a display cross and one as a processional cross. The processional cross is then placed near the pulpit or the altar/table. If two are used one is appropriately the Greek form and the other Latin. Crosses should be especially fine works of art. See Facility Plates 21 and 22, pages 37.06-81 and 37.06-83.

b. Jewish Symbols. A common symbol of Judaism is the menorah, a seven branched candlestick. This may be of substantial size and in various geometries or sculptural forms. It stands on the floor, or may be wall mounted. See Facility Plate 23, page 37.06-85. Two other Jewish symbols are the Tablets of the Law with Hebrew inscriptions and the hexagram. (These are also used by Christians.)

c. Islamic Devices. It is conventional that banners or rigid devices carrying devotional inscriptions in arabic are placed over the mihrab, over the pulpit dais (member) and over the main portal in muslim places of worship. Details of such devices may be obtained from the North American Islamic Trust, Inc., 10900 W. Washington St., Indianapolis, IN 46231.

d. Stations of the Cross. A devotional practice common among Roman Catholics but used by other Christians also is a prayer sequence memorializing the passion of Jesus. The service is enriched by movement along the Path of the Cross consisting of fourteen stations, each of which is conventionally given a location marked by an image or a symbol. In a military chapel these cannot be permanently fixed. However, planning should include provision for hanging or emplacing the marks of the stations. The devices themselves, kept in storage

between times, should be well made and durable art works; they may range from bronze sculpture to something as simple as carefully made Roman numerals in wood, and they may be placed at the floor as well as on walls.

e. The Tabernacle. The eucharistic bread consecrated but not consumed at Catholic mass is preserved for use at subsequent masses or for distribution to people who are ill or otherwise unable to attend mass. Catholic piety values the privileges of praying in the presence of this Sacramental Body, and therefore it is kept in a container called a tabernacle, in an accessible but private place. The tabernacle, being a treasury, is usually of metal, beautifully and carefully designed, well made, and lockable. It may be cylindrical in shape or a rectilinear box. In either case the opening is on a vertical surface and is usually a pair of doors. Ciboria, which are goblet-like vessels in which eucharistic breads are kept, are placed in the tabernacle.

The tabernacle is secured firmly in place. It may be on a pedestal about 4 feet (1200 mm) high or on a shelf or bracket. Near at hand, perhaps as part of the pedestal, is a shelf; this is necessary so that a person can remove the ciboria, set them down, close the tabernacle and then lift them again from the shelf.

Associated with the tabernacle is a lamp in which a flame burns whenever the Reserved Host is present in the tabernacle. It may be suspended nearby or otherwise mounted. The lamp usually consists of wax in a glass cylinder slightly less than 3 inches (75 mm) in diameter and a little more than 9 inches (225 mm) tall. It is normally set into a second glass cylinder which is usually red, but need not be. This lamp may, as an alternative, burn oil, in which case dimensions may be chosen at will. See Facility Plate 24, page 37.06-87.

f. Candlesticks. Flame, as symbols of the spirit and the sign of celebration is a universal complement of liturgy. Aside from menorahs, the number of candles is not rigidly established but two or four are present even in small chapels. Because altar/tables are free standing anything set on the surface may interrupt visibility, so floor-standing candlesticks are preferred. They consist of candle holder and drip cup, staff and base, and many varieties are possible. If the base is separable from the staff, candles can be carried in procession as torches; the staff is then set in a socket in the base, or otherwise secured. The candles used are usually white and about 2 inches (50 mm) in diameter. Their holder is about 40 inches (1000 mm) above the floor. See Facility Plate 25, page 37.06-89.

A special candlestick and candle reminiscent of resurrection and called the baptismal or paschal candle is provided to stand, during

Christian liturgies, at the place of baptism. During the Easter Season it is placed near the altar/table, and at funerals at the head of the bier. The candlestick is about 50 inches (1250 mm) tall. The candle is a special one intended to last a year. It is usually about 2 inches (50 mm) in diameter but other dimensions are possible. Candlesticks often feature prickets rather than sockets to secure the candles, which can then be of various sizes. See Facility Plate 26, page 37.06-91.

g. Fabrics. For many Christian liturgies a colored tablecloth is laid on the altar/table, its color and detail varying with the seasons of the year. These paraments take various forms; they may only partly cover the table, or they may be "throws" which hang to the floor on all sides. They may carry symbolic devices or they may be plain colors. Four colors are normally supplied: white, green, red and purple. Blue is added in some traditions, and black frequently. It is proper that the designer be involved in the design of these fabrics or in selection of an artist for their design.

An antependium, which is a fabric that hangs in front of the pulpit, is also often used in a design and color to match the other fabrics. It is commonly the width of the bookrest; its hanging length is an aesthetic judgment.

Designers may choose to use banners or to use fabrics in other ways. A rug or fabric runner may be laid on the platform to muffle the footsteps of the leaders of worship. Fabrics may be used for acoustical, symbolic, or aesthetic goals. Many fabrics used in liturgies, such as fair linens and towels, will not concern the designer.

Traditional fabric dossal curtain and reredos shall not be used. These features were adjuncts to the altar when its location was the remotest point in a chancel or choir. Altar/tables now stand free in space. The action of the liturgy is the proper focus of a place of worship; any architectural feature that presumes to be the focus of the room by its visual dominance and thus draws attention away from the liturgical action, is improper.

h. Special Works of Art. Although sectarian symbols are not to be permanently set in spaces of flexible use, works of art of various kinds may be introduced so long as they are of worthy quality and not beyond the practice in the civilian sector. This applies not only to those areas of the facility associated with worship but also to spaces in which religious education is conducted.

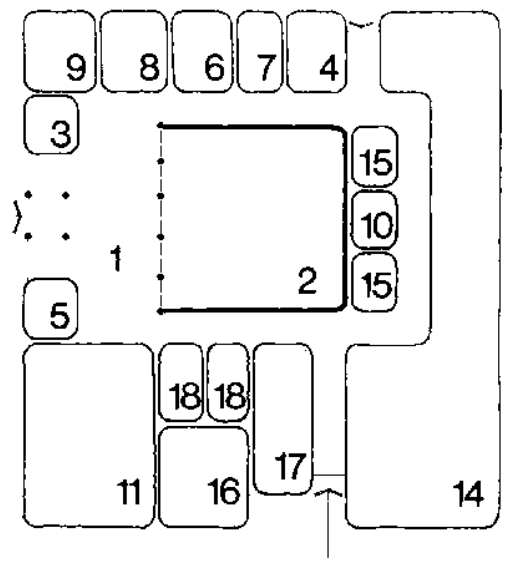
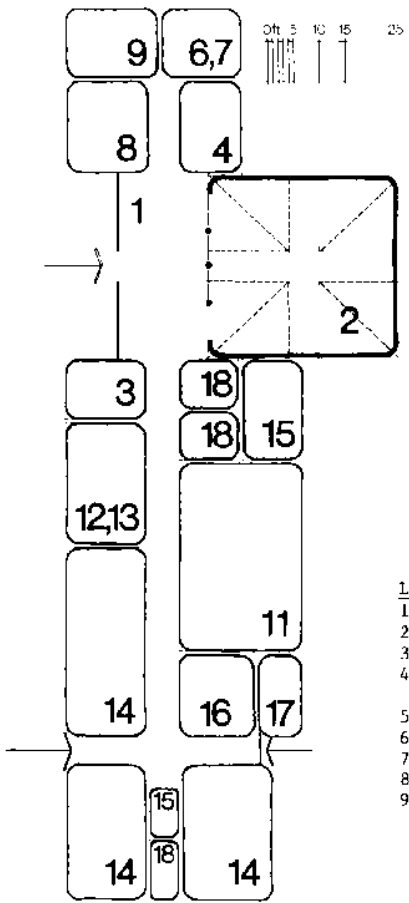

LEGEND

- | | |
|-------------------------------------|---------------------------------|
| 1. Concourse | 10. Rear Screen Projection Room |
| 2. Place of Worship | 11. Social Hall |
| 3. Chapel of Reservation | 12. Music Room |
| 4. Ecclesiastical Artifacts Storage | 13. Meetings & Teaching |
| 5. Usher's Storage | 14. Religious Education |
| 6. Sacristy | 15. Storage |
| 7. Vestry | 16. Kitchen |
| 8. Administrative Staff | 17. Mechanical, Custodial |
| 9. Chaplain's Office | 18. Toilets |

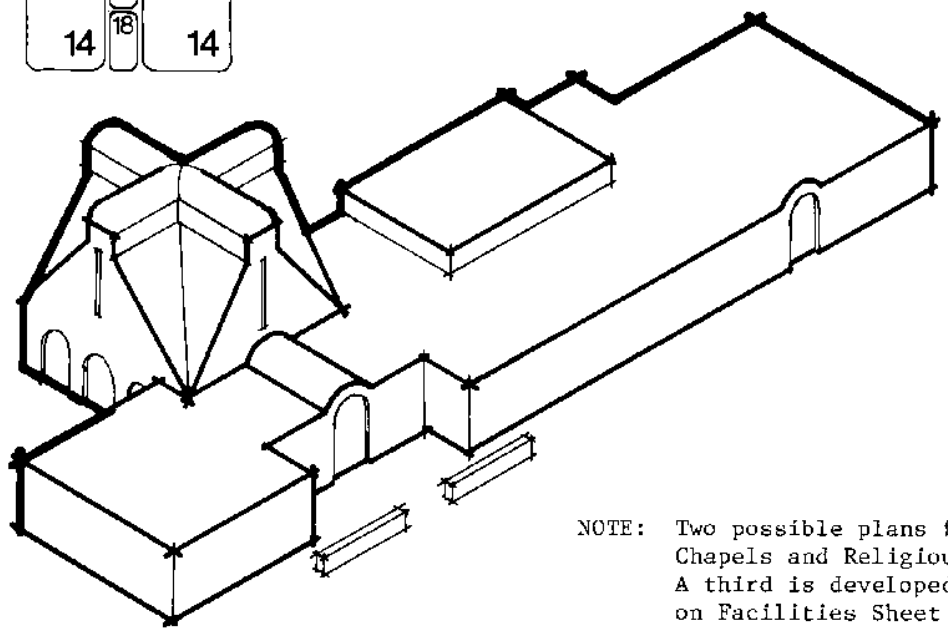

NOTE: Two possible plans for 100 Seat Chapels and Religious Education. A third is developed and shown on Facilities Sheet 2.

TITLE	DATE	FACILITY PLATE NO.	SHEET
Plan Studies 100 Seat Chapel with Related Religious Educational Facilities	11/83	Chapel: 730-83 Rel. Educ. Fac.: 730-84	1

PAGE 42 INTENTIONALLY BLANK

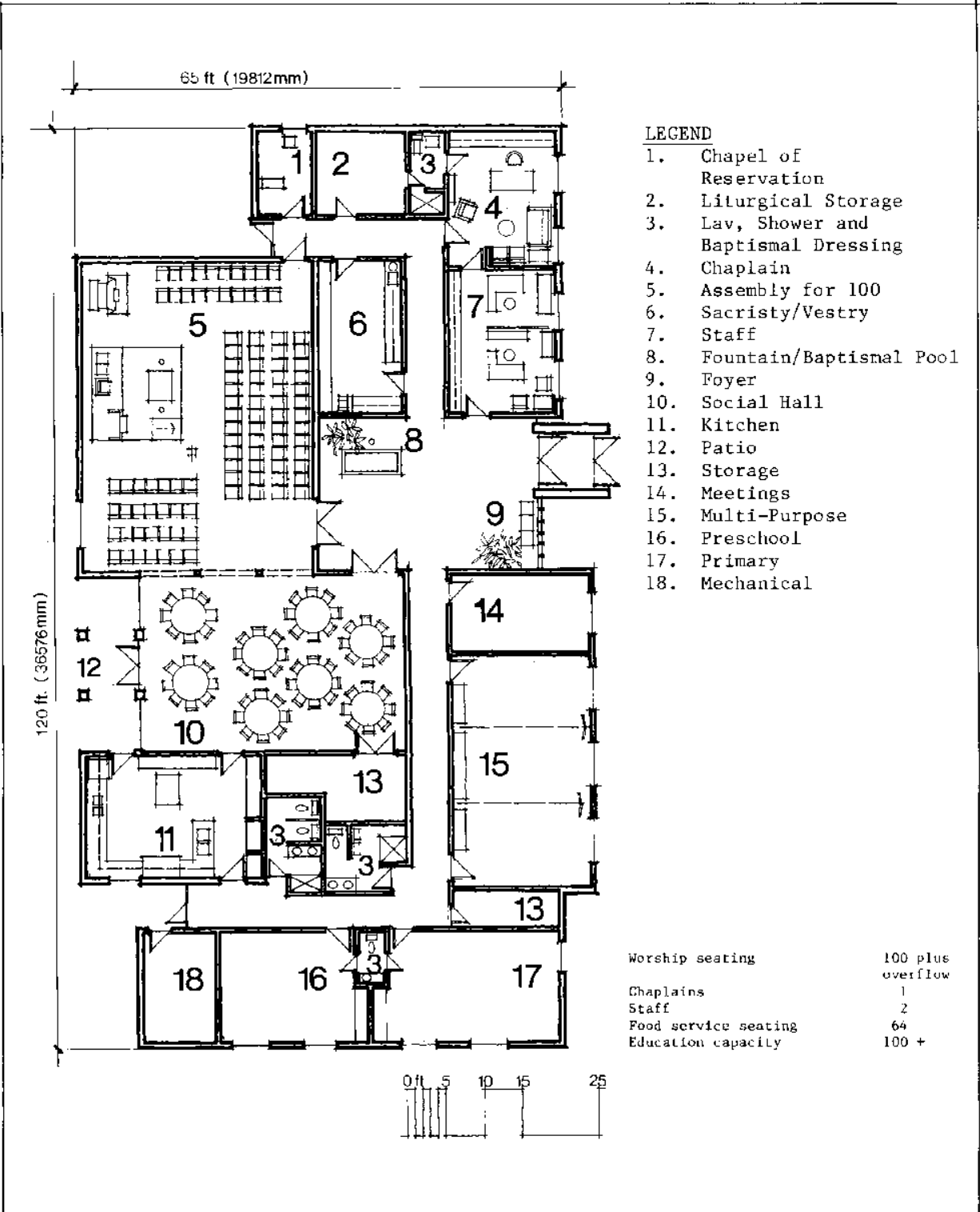

- LEGEND**
- 1. Chapel of Reservation
 - 2. Liturgical Storage
 - 3. Lav, Shower and Baptismal Dressing
 - 4. Chaplain
 - 5. Assembly for 100
 - 6. Sacristy/Vestry
 - 7. Staff
 - 8. Fountain/Baptismal Pool
 - 9. Foyer
 - 10. Social Hall
 - 11. Kitchen
 - 12. Patio
 - 13. Storage
 - 14. Meetings
 - 15. Multi-Purpose
 - 16. Preschool
 - 17. Primary
 - 18. Mechanical

Worship seating	100 plus overflow
Chaplains	1
Staff	2
Food service seating	64
Education capacity	100 +

<p>TITLE</p> <p>Developed Plan for 100 Seat Chapel and Related Religious Educational Facilities</p>	<p>DATE</p> <p>11/83</p>	<p>FACILITY PLATE NO.</p> <p>Chapel: 730-83 Rel. Educ. Fac.: 730-84</p>	<p>SHEET</p> <p>2</p>
--	---------------------------------	--	-------------------------------------

PAGE 44 INTENTIONALLY BLANK

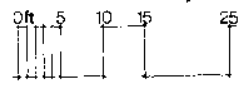
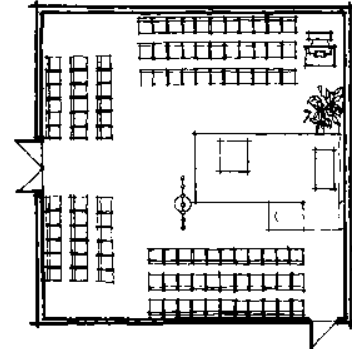
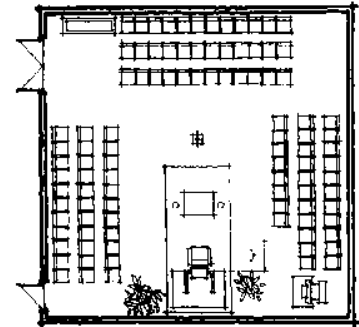
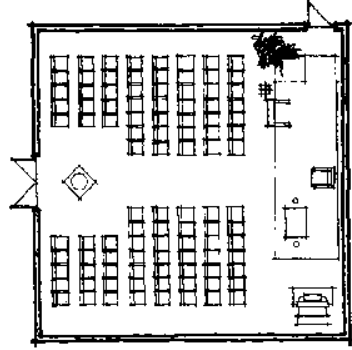
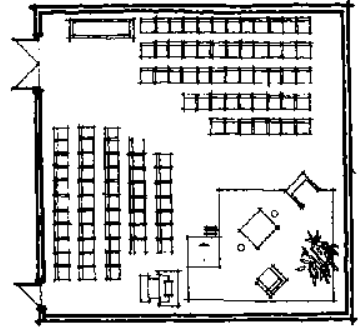
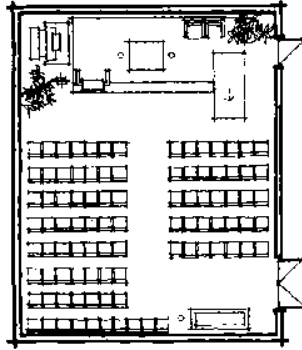
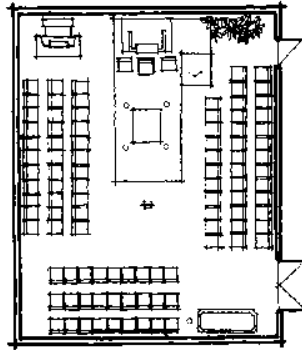

TITLE	DATE	FACILITY PLATE NO.	SHEET
Various Configurations for a 100 seat Chapel	11/83	Chapel: 730-83 Rel. Educ. Fac.: 730-84	3

PAGE 46 INTENTIONALLY BLANK

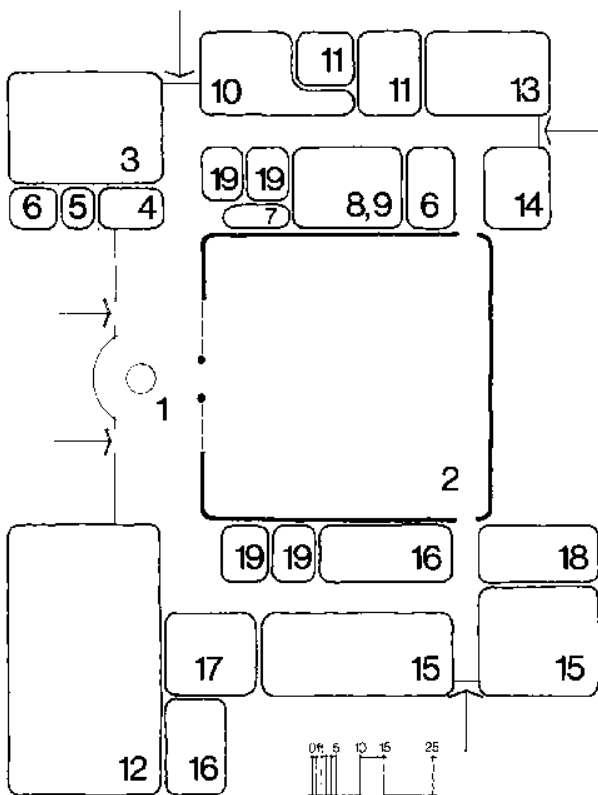
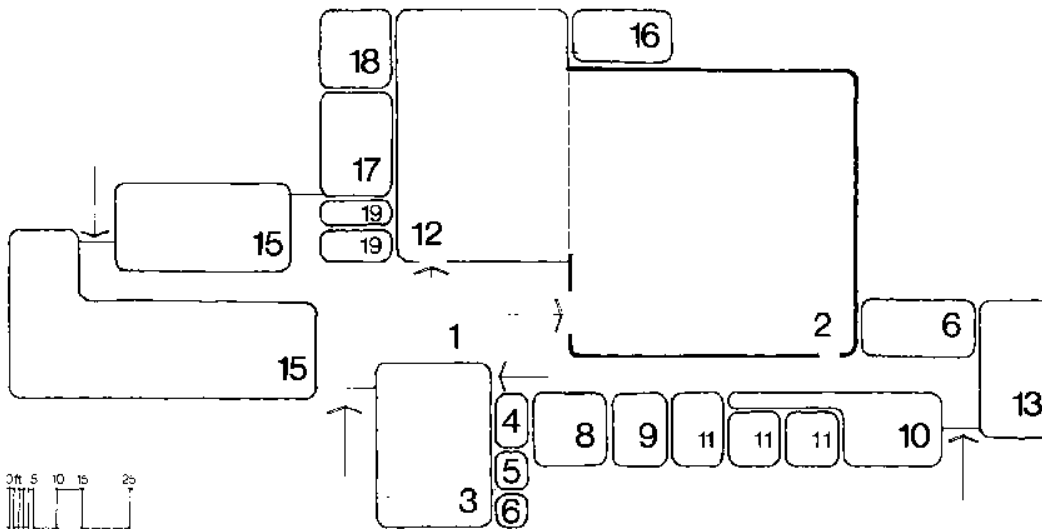

LEGEND

- 1. Concourse
- 2. Place of Worship
- 3. Smaller Chapel
- 4. Chapel of Reservation
- 5. Reconciliation Room
- 6. Ecclesiastical Artifacts Storage
- 7. Usher's Storage
- 8. Sacristy
- 9. Vestry
- 10. Administrative Staff
- 11. Chaplains' Offices
- 12. Social Hall
- 13. Music Room
- 14. Meetings & Teaching
- 15. Religious Education
- 16. Storage
- 17. Kitchen
- 18. Mechanical, Custodial
- 19. Toilets

NOTE: Two possible plans for 300 Seat Chapels and Religious Education. A third is developed and shown on Facilities Sheet 5.

TITLE	DATE	FACILITY PLATE NO.	SHEET
Plan Studies for 300 Seat Chapel with Related Religious Educational Facilities	11/83	Chapel: 730-83 Rel. Educ. Fac.: 730-84	4

PAGE 48 INTENTIONALLY BLANK

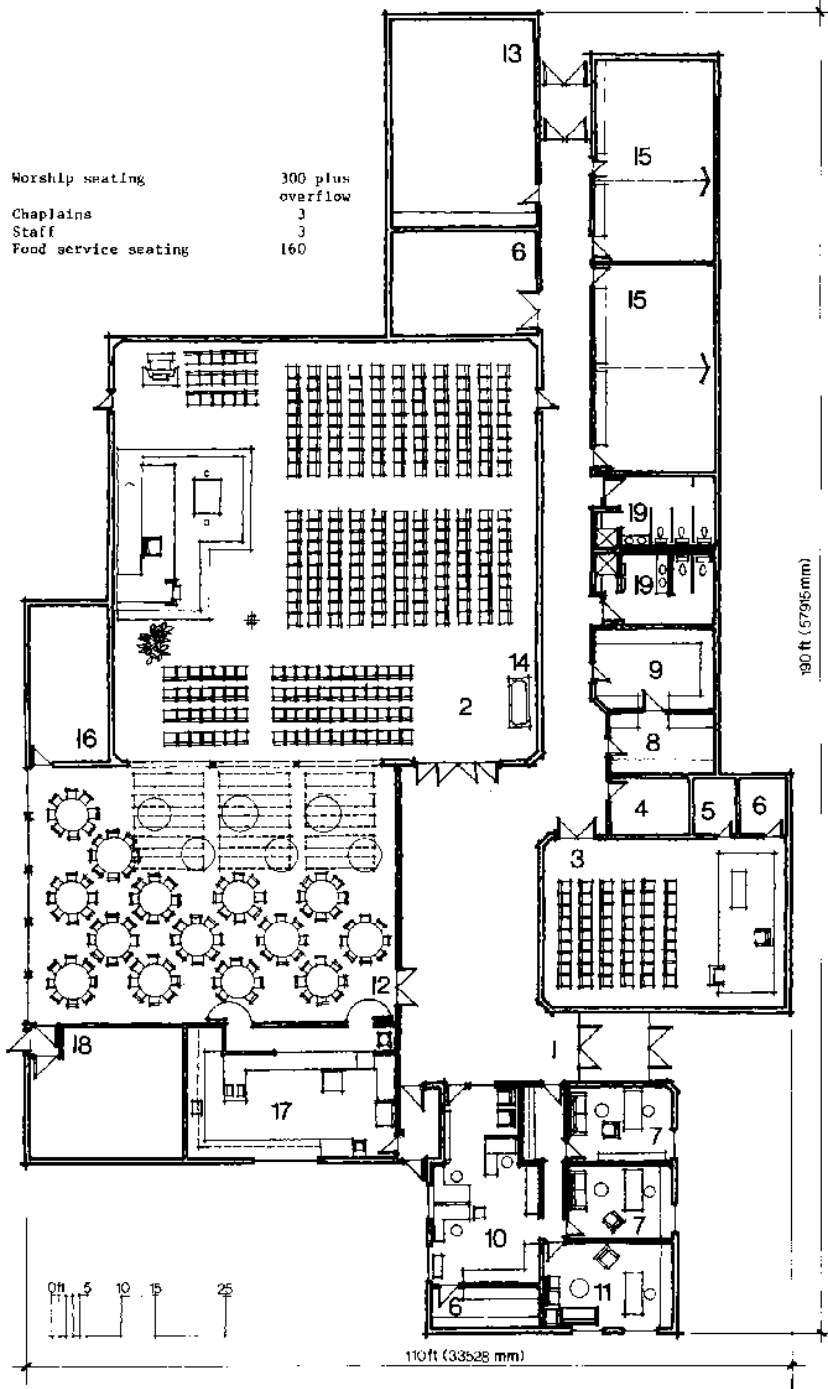

Worship seating 300 plus overflow
 Chaplains 3
 Staff 3
 Food service seating 160

190ft (57916mm)

110ft (33528 mm)

LEGEND

- 1. Concourse
- 2. Place of Worship
- 3. Smaller Chapel
- 4. Chapel of Reservation
- 5. Reconciliation Room
- 6. Ecclesiastical Artifacts Storage
- 7. Chaplains' Offices: Junior
- 8. Sacristy
- 9. Vestry
- 10. Administrative Staff
- 11. Chaplain's Office; Senior
- 12. Social Hall (Subdivisible)
- 13. Music Room
- 14. Baptismal Pool
- 15. Religious Education
- 16. Storage
- 17. Kitchen
- 18. Mechanical, Custodial
- 19. Toilet w/Shower & Baptismal Dressing

TITLE	DATE	FACILITY PLATE NO.	SHEET
Developed Plan for 300 Seat Chapel and Related Religious Educational Facilities	11/83	Chapel: 730-83 Rel. Educ. Fac.: 730-84	5

PAGE 50 INTENTIONALLY BLANK

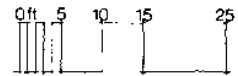
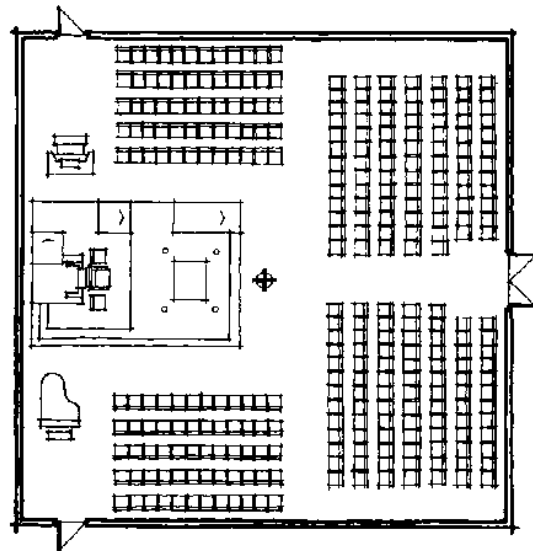
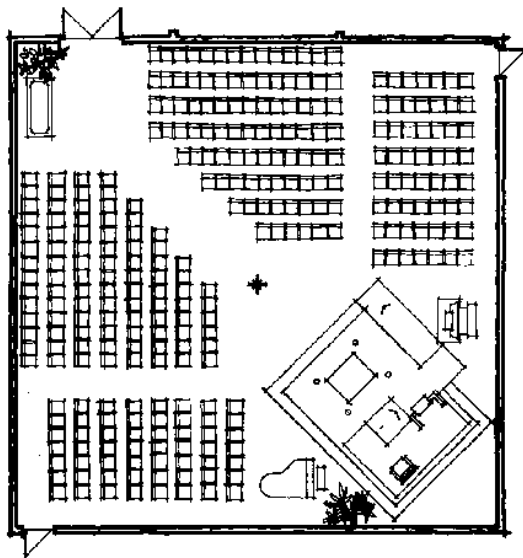
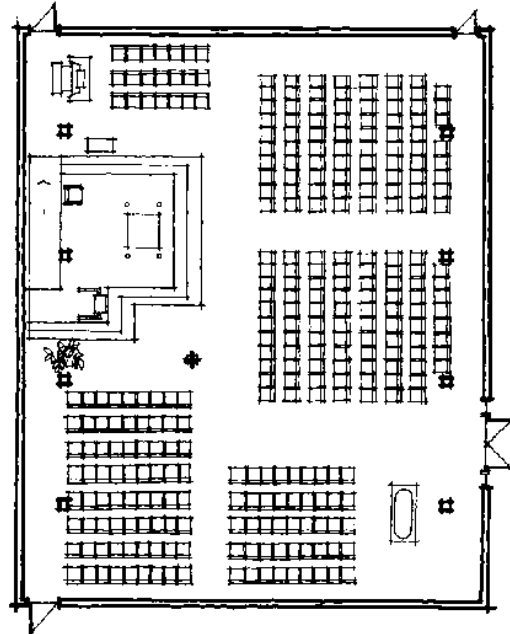
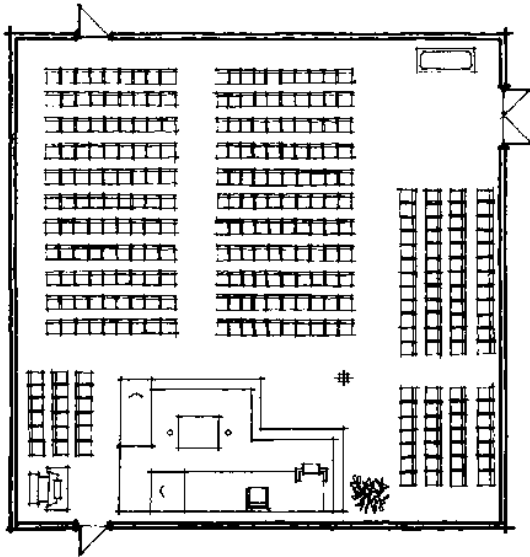

TITLE	DATE	FACILITY PLATE NO.	SHEET
Various Configurations for a 300 Seat Chapel	11/83	Chapel: 730-83 Rel. Educ. Fac.: 730-84	6

PAGE 52 INTENTIONALLY BLANK

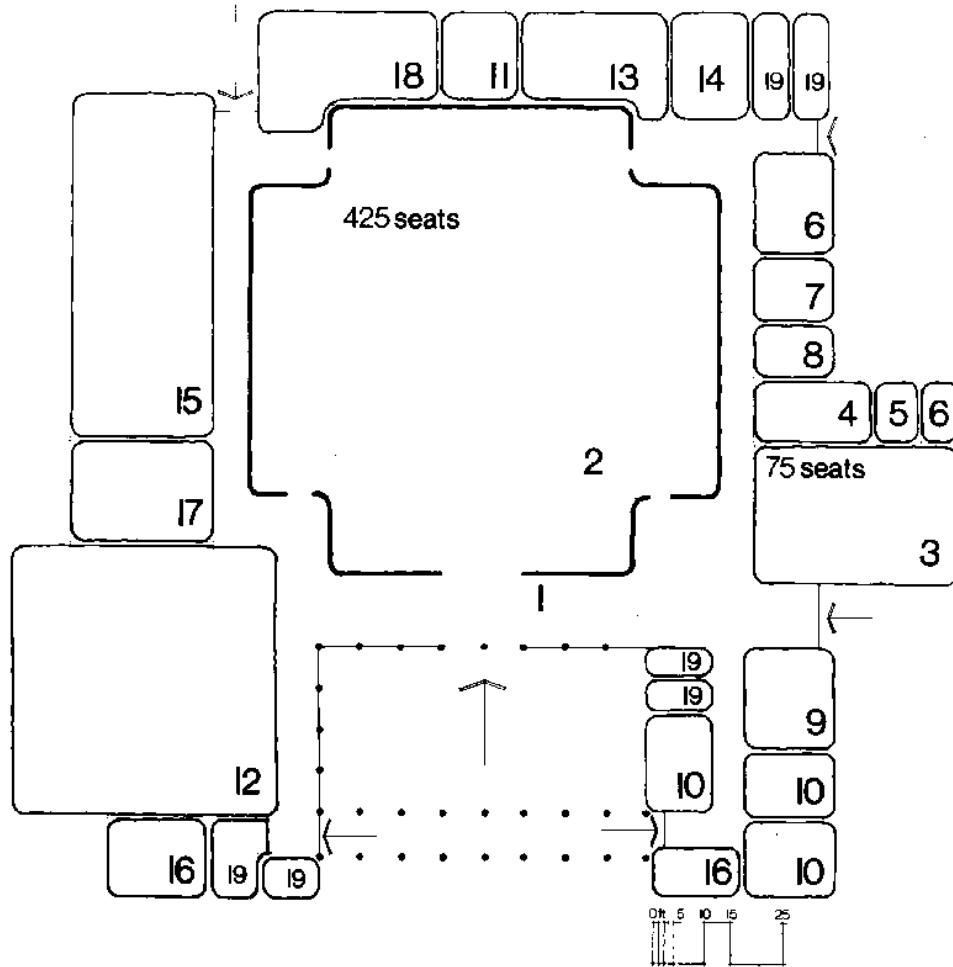

LEGEND

- | | |
|-------------------------------------|---------------------------------|
| 1. Concourse | 11. Rear Screen Projection Room |
| 2. Place of Worship | 12. Social Hall |
| 3. Smaller Chapel | 13. Music Room |
| 4. Chapel of Reservation | 14. Meetings & Teaching |
| 5. Reconciliation Room | 15. Religious Education |
| 6. Ecclesiastical Artifacts Storage | 16. Storage |
| 7. Sacristy | 17. Kitchen |
| 8. Vestry | 18. Mechanical, Custodial |
| 9. Administrative Staff | 19. Toilets |
| 10. Chaplain's Office | |

NOTE: One possible plan for 500 Seat Chapel and Religious Education. A second is shown on Facilities Sheet 8 and a third is developed and shown on Facilities Sheet 9.

TITLE	DATE	FACILITY PLATE NO.	SHEET
Plan Study for a Chapel Seating 500, a Second Chapel Seating 75 and Related Religious Educational Facilities	11/83	Chapel: 730-83 Rel. Educ. Fac.: 730-84	7

PAGE 54 INTENTIONALLY BLANK

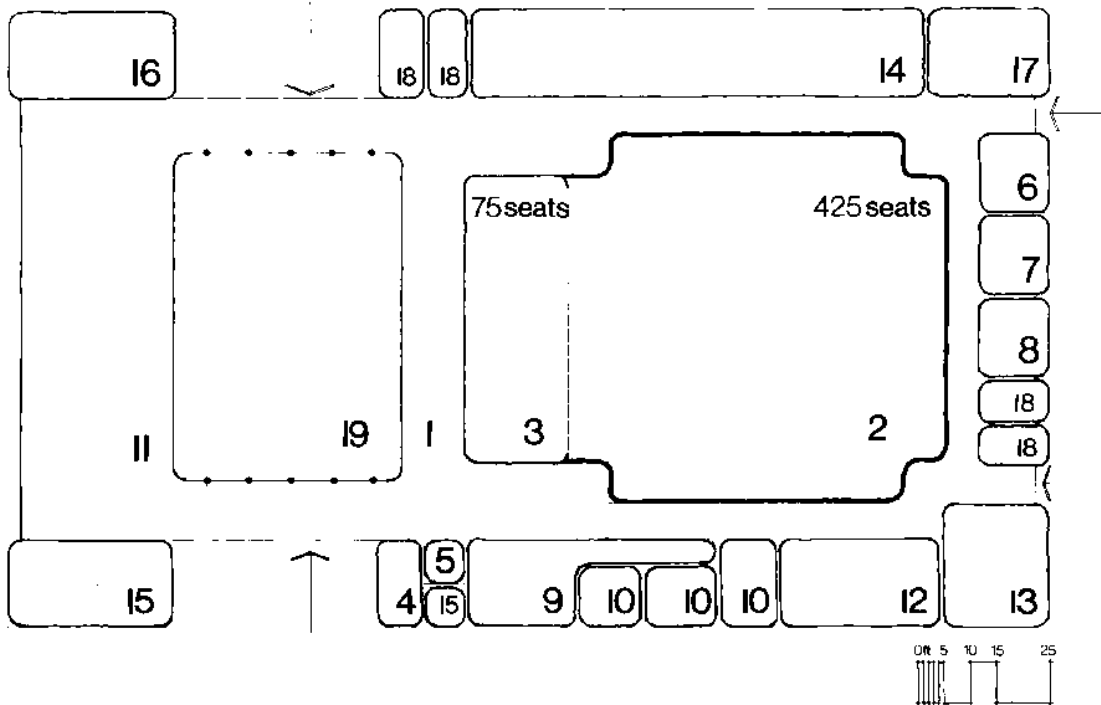

LEGEND

- | | |
|-------------------------------------|---------------------------|
| 1. Concourse | 11. Social Hall |
| 2. Place of Worship | 12. Music Room |
| 3. Smaller Chapel | 13. Meetings & Teaching |
| 4. Chapel of Reservation | 14. Religious Education |
| 5. Reconciliation Room | 15. Storage |
| 6. Ecclesiastical Artifacts Storage | 16. Kitchen |
| 7. Sacristy | 17. Mechanical, Custodian |
| 8. Vestry | 18. Toilets |
| 9. Administrative Staff | 19. Outdoor Court |
| 10. Chaplain's Office | |

NOTE: One possible plan for 500 Seat Chapel and Religious Education. A second is shown on Facilities Sheet 7 and a third is developed and shown on Facilities Sheet 9.

TITLE	DATE	FACILITY PLATE NO.	SHEET
Plan Study for a Chapel Seating 500 with Related Religious Educational Facilities	11/83	Chapel: 730-83 Rel. Educ. Fac.: 730-84	8

PAGE 56 INTENTIONALLY BLANK

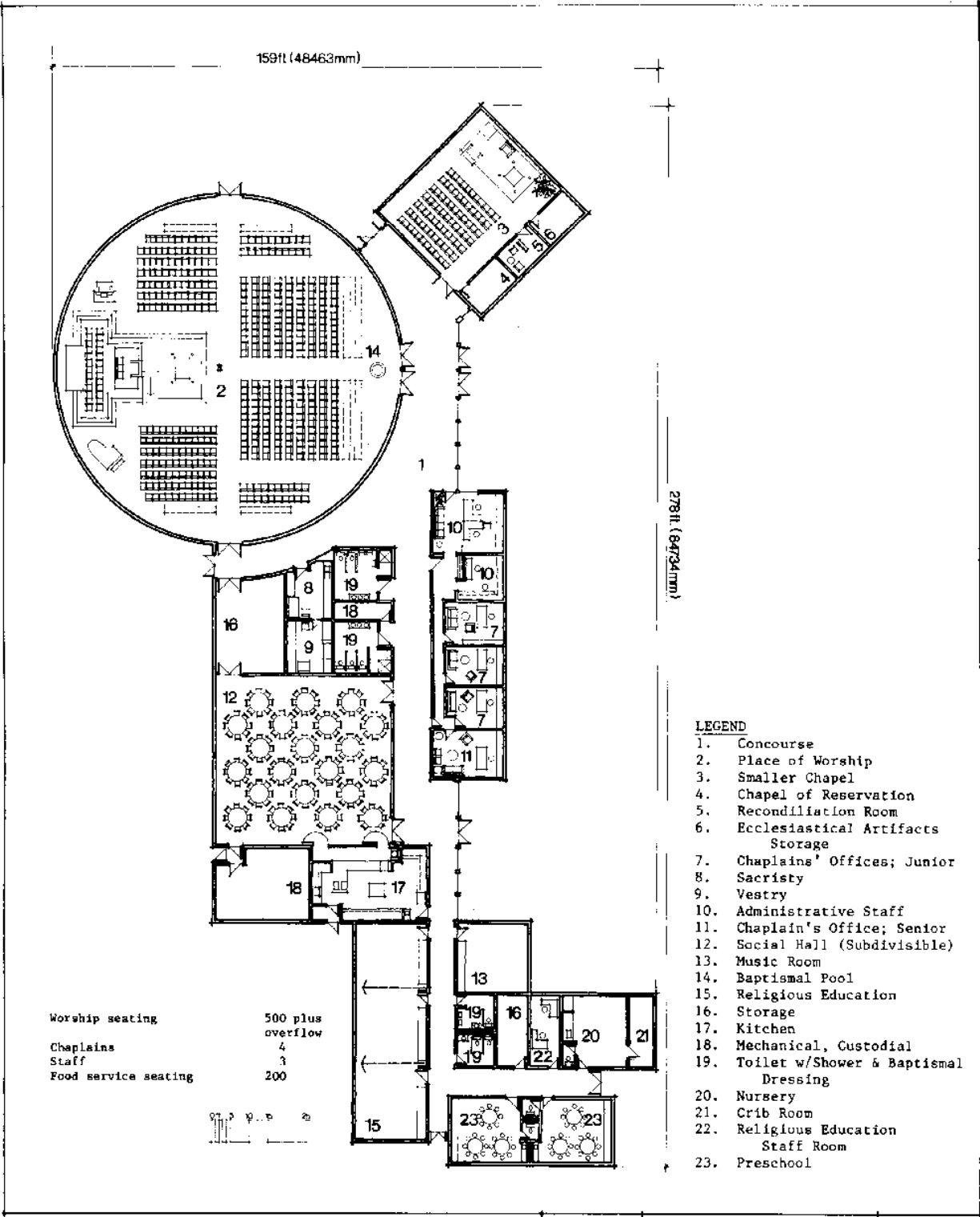

Worship seating 500 plus overflow
 Chaplains 4
 Staff 3
 Food service seating 200

- LEGEND**
- 1. Concourse
 - 2. Place of Worship
 - 3. Smaller Chapel
 - 4. Chapel of Reservation
 - 5. Reconciliation Room
 - 6. Ecclesiastical Artifacts Storage
 - 7. Chaplains' Offices; Junior
 - 8. Sacristy
 - 9. Vestry
 - 10. Administrative Staff
 - 11. Chaplain's Office; Senior
 - 12. Social Hall (Subdivisible)
 - 13. Music Room
 - 14. Baptismal Pool
 - 15. Religious Education
 - 16. Storage
 - 17. Kitchen
 - 18. Mechanical, Custodial
 - 19. Toilet w/Shower & Baptismal Dressing
 - 20. Nursery
 - 21. Crib Room
 - 22. Religious Education Staff Room
 - 23. Preschool

TITLE	DATE	FACILITY PLATE NO.	SHEET
Developed Plan for 500 Seat Chapel with Related Religious Educational Facilities	11/83	Chapel: 730-83 Rel. Educ. Fac.: 730-84	9

PAGE 58 INTENTIONALLY BLANK

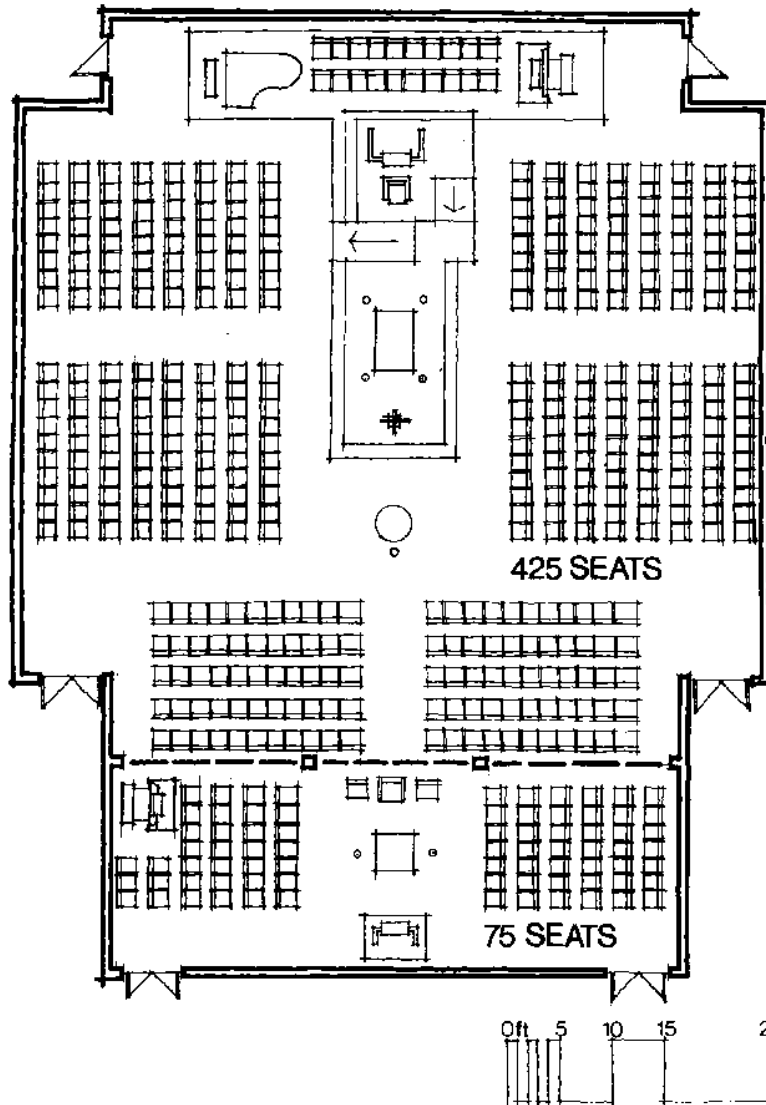

TITLE	DATE	FACILITY PLATE NO.	SHEET
Configuration for a Chapel with an Internal Subdivision Seating 425 and 75 in Its Parts	11/83	Chapel: 730-83 Rel. Educ. Fac.: 730-84	10

PAGE 60 INTENTIONALLY BLANK

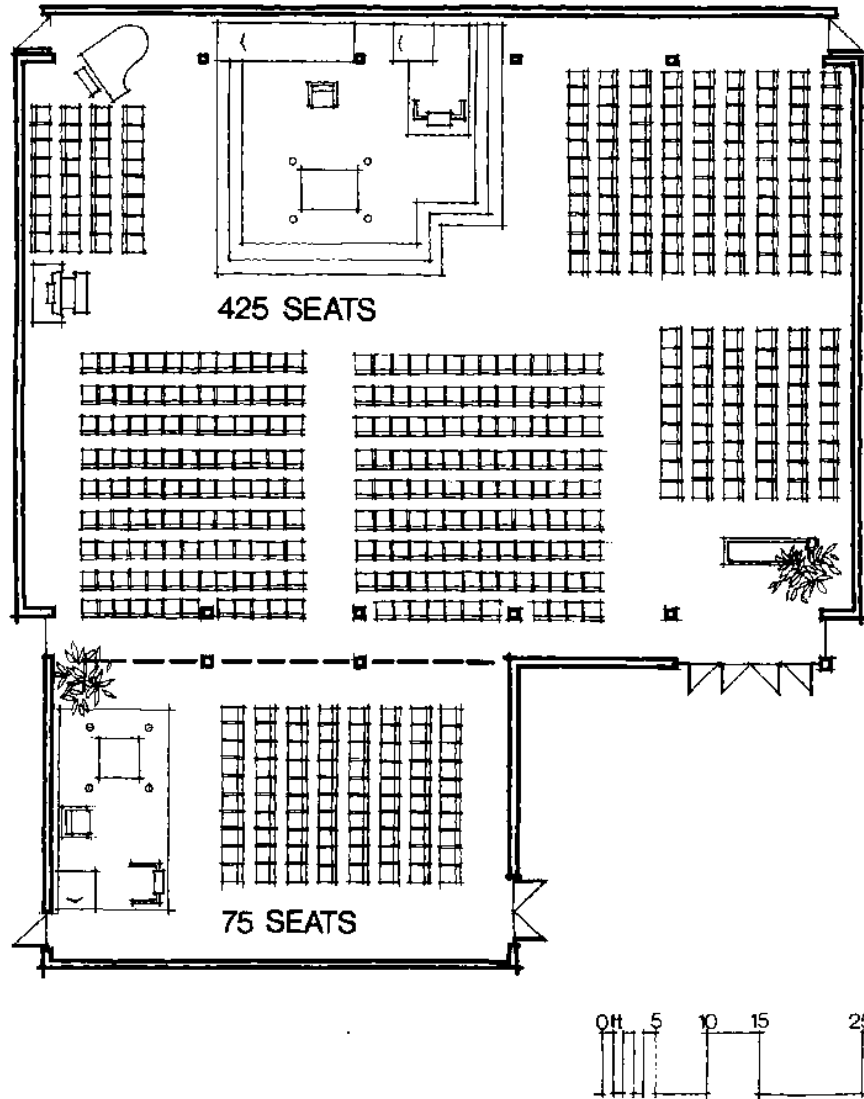

TITLE	DATE	FACILITY PLATE NO.	SHEET
Configuration for a Chapel with an Internal Subdivision Seating 425 and 75 in Its Parts	11/83	Chapel: 730-83 Rel. Educ. Fac.: 730-84	11

PAGE 62 INTENTIONALLY BLANK

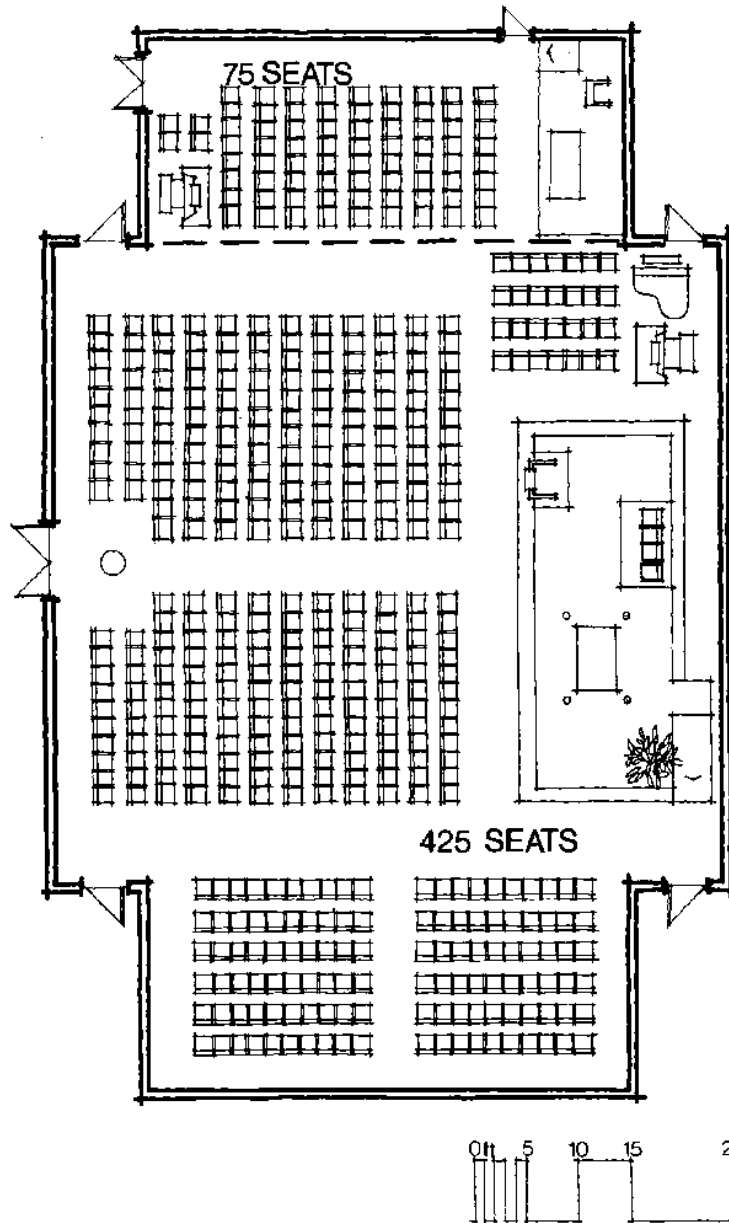

TITLE	DATE	FACILITY PLATE NO.	SHEET
Configuration for a Chapel with an Internal Subdivision Seating 425 and 75 in Its Parts	11/83	Chapel: 730-83 Rel. Educ. Fac.: 730-84	12

PAGE 64 INTENTIONALLY BLANK

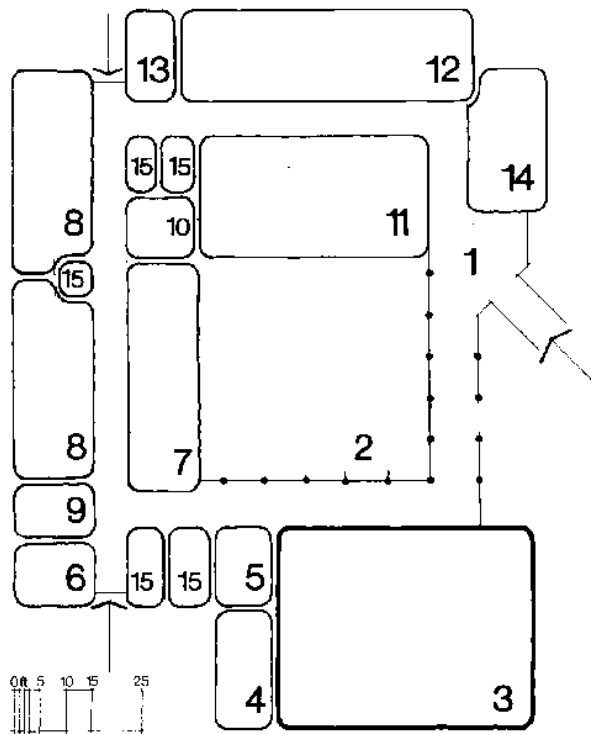

LEGEND

1. Entry & Gallery
2. Courtyard
3. Assembly & Activity
4. Storage
5. Kitchen
6. Mechanical
7. Crafts
8. Small Children
9. Janitor
10. Storage
11. Lounge
12. Games, Music, TV, etc.
13. Vending
14. Staff
15. Toilets

TITLE	DATE	FACILITY PLATE NO.	SHEET
Plan Study for an Unattached Religious Educational Facility of 10,000 Square Feet	11/83	Chapel: 730-83 Rel. Educ. Fac.: 730-84	13

PAGE 66 INTENTIONALLY BLANK

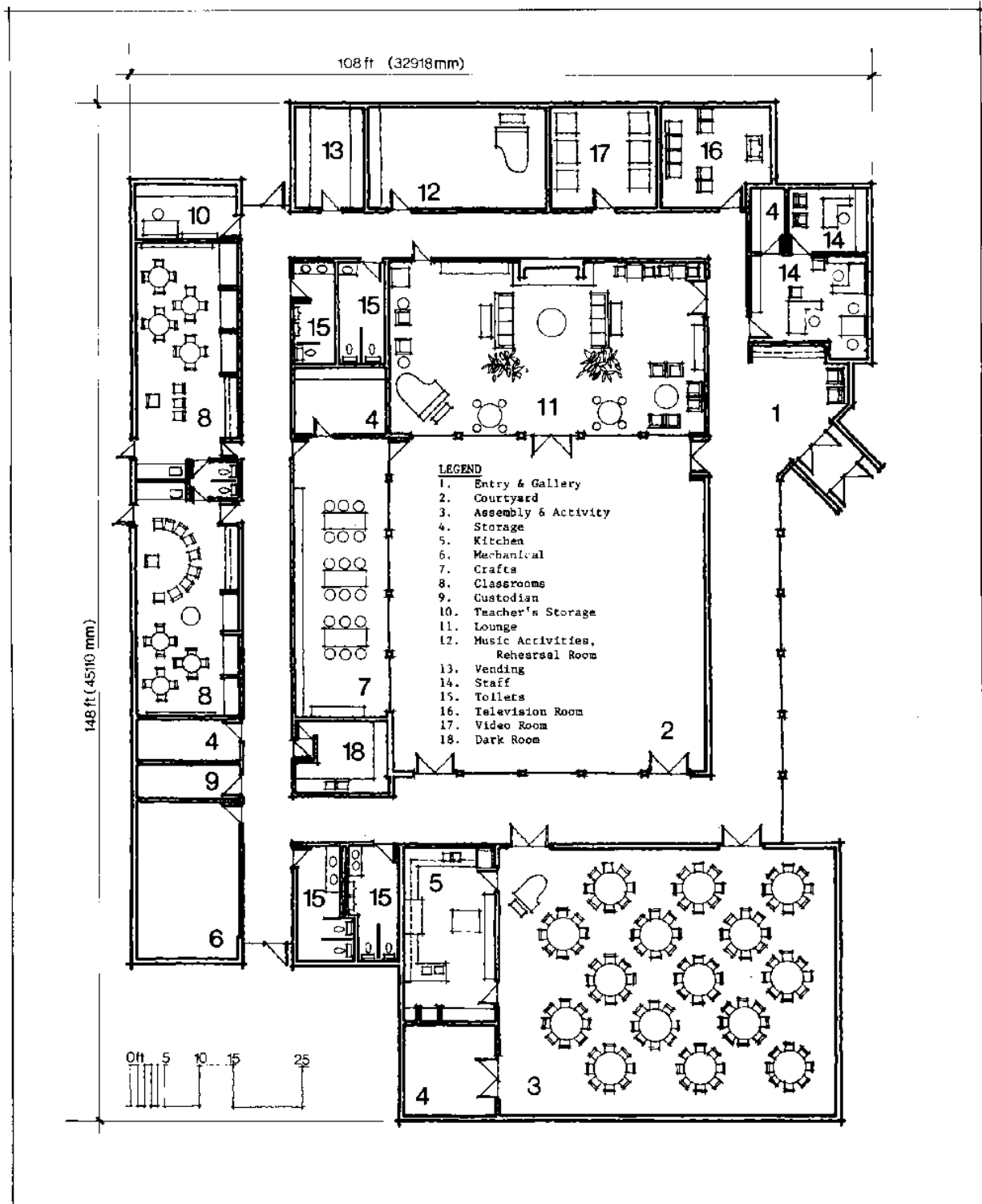

TITLE	DATE	FACILITY PLATE NO.	SHEET
Developed Plan for an Unattached Religious Educational Facility	11/83	Chapel: 730-83 Rel. Educ. Fac.: 730-84	14

PAGE 68 INTENTIONALLY BLANK

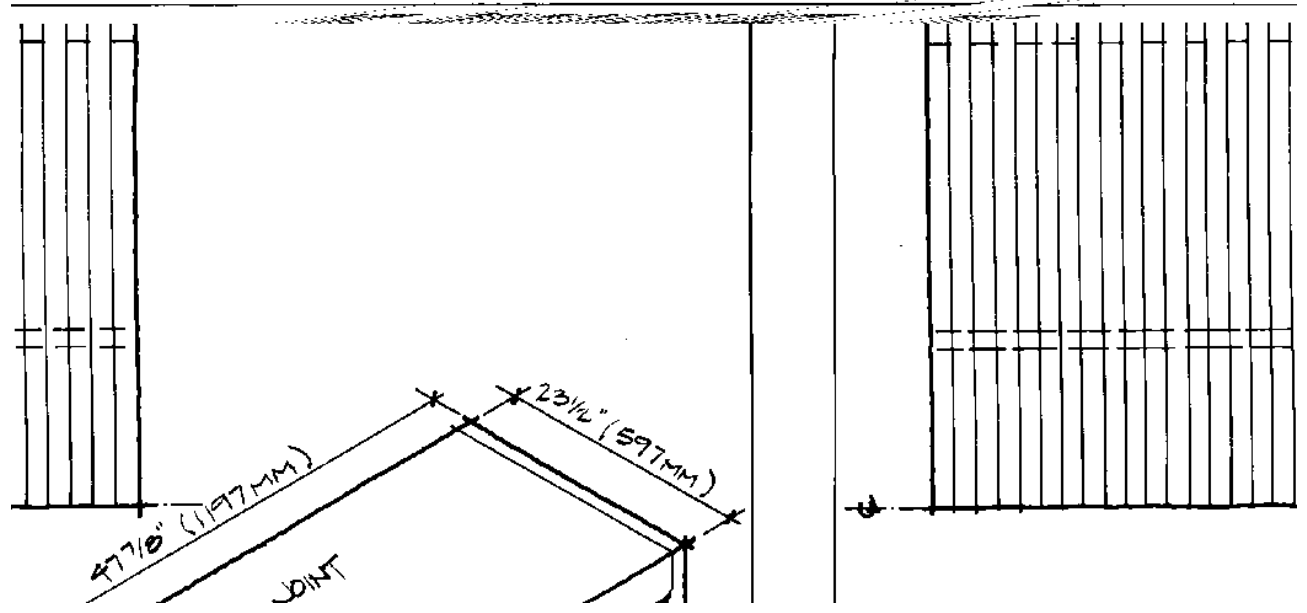
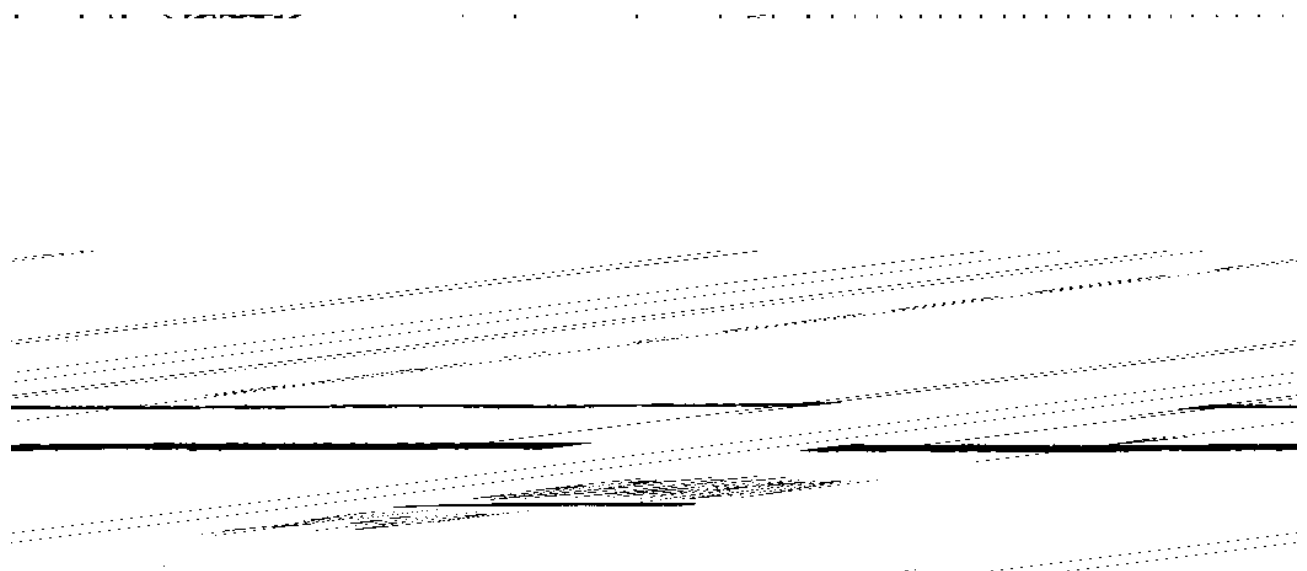
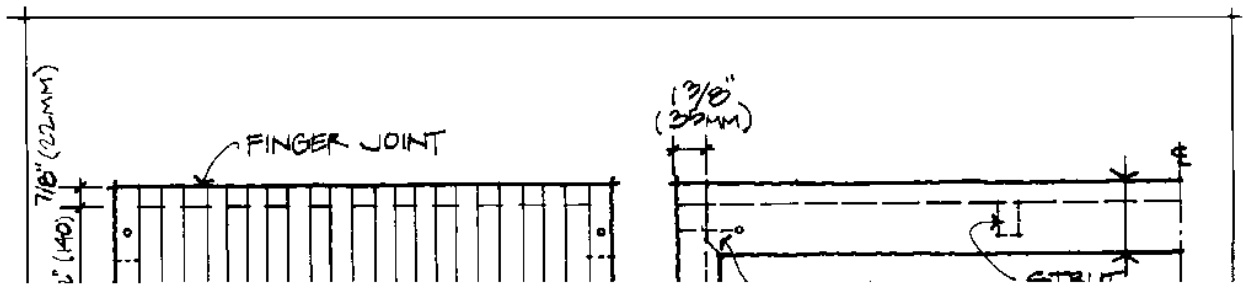

PAGE 70 INTENTIONALLY BLANK

PAGE 72 INTENTIONALLY BLANK

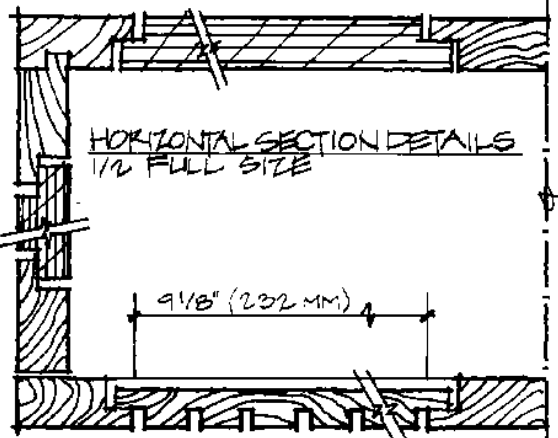
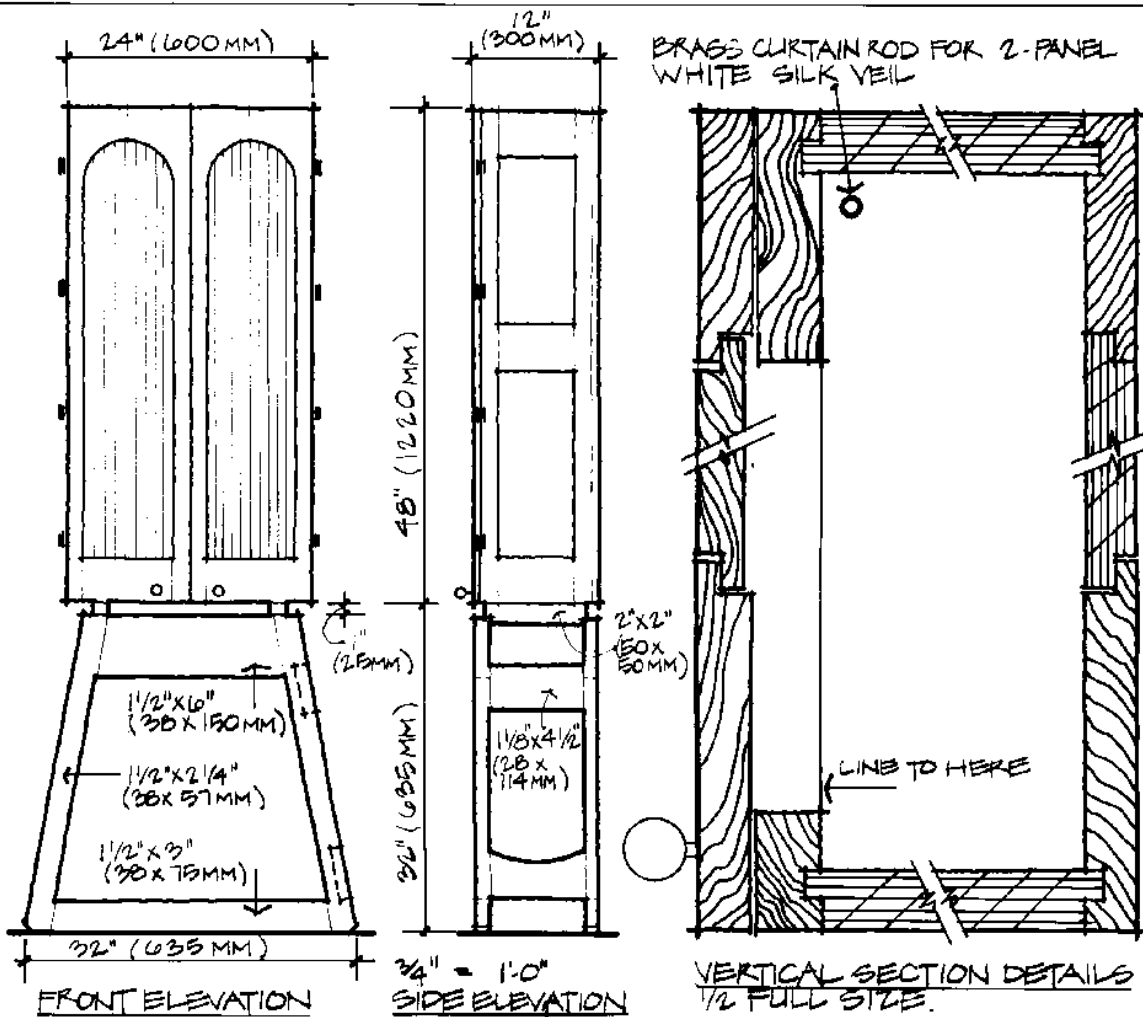

- NOTES: 8 NOS. 3/4" (19MM) BRONZE OLIVE KNUCKLE HINGES.
- PLYWOOD IS RIFT OR OTHER STRAIGHT GRAN, NO ROTARY CUT.
 - INTERIOR TO BE LINED WITH VIOLET OR VERMILLION VELOUR, TOP FLOOR, SIDES UP TO FACE FRAME, ALSO INSIDE PANELS OF DOORS.
 - BRONZE DOOR KNOBS 3/4" (19MM) DIAMETER
 - 2 MAGNETIC LATCHES.
 - ROUND ALL CORNERS OF BASE FRAME 1/4" (6MM) RADIUS

TITLE	DATE	FACILITY PLATE NO.	SHEET
Ark	11/83	Chapel: 730-83 Rel. Educ. Fac.: 730-84	17

PAGE 74 INTENTIONALLY BLANK

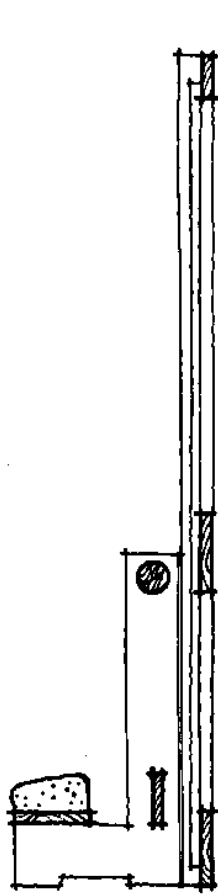

SECTION
3/4" TO 1'-0"

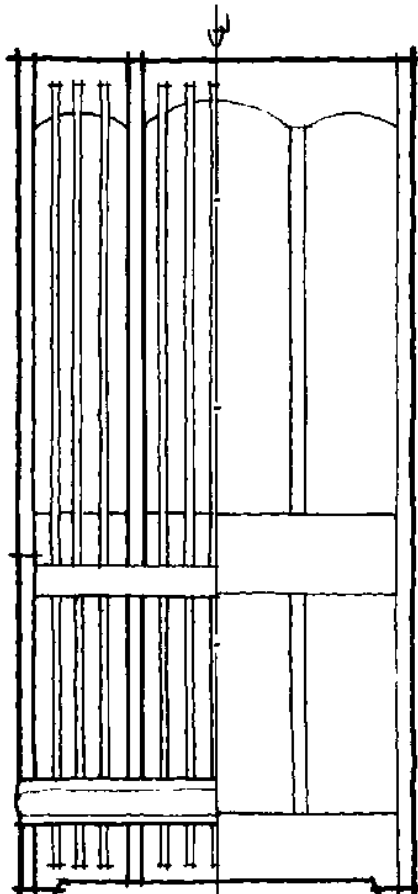

1/2 FRONT
ELEVATION
3/4" TO 1'-0"

1/2 REAR
ELEVATION

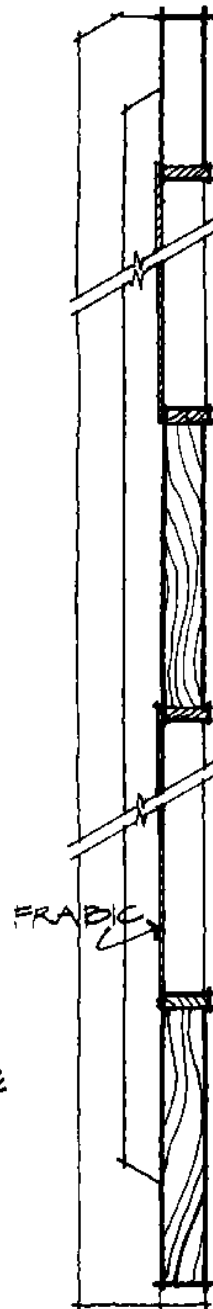

FABRIC

VERTICAL
SECTION 3" TO 1'-0"

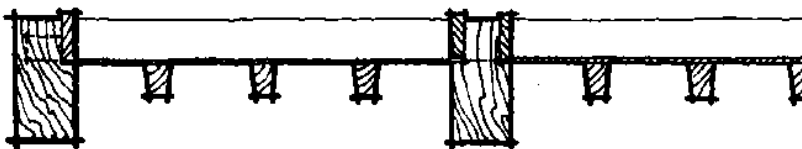

HORIZONTAL SECTION
3" TO 1'-0"

TITLE	DATE	FACILITY PLATE NO.	SHEET
Portable Screen for Reconciliation Rites with Kneeler	11/83	Chapel: 730-83 Rel. Educ. Fac.: 730-84	18

PAGE 76 INTENTIONALLY BLANK

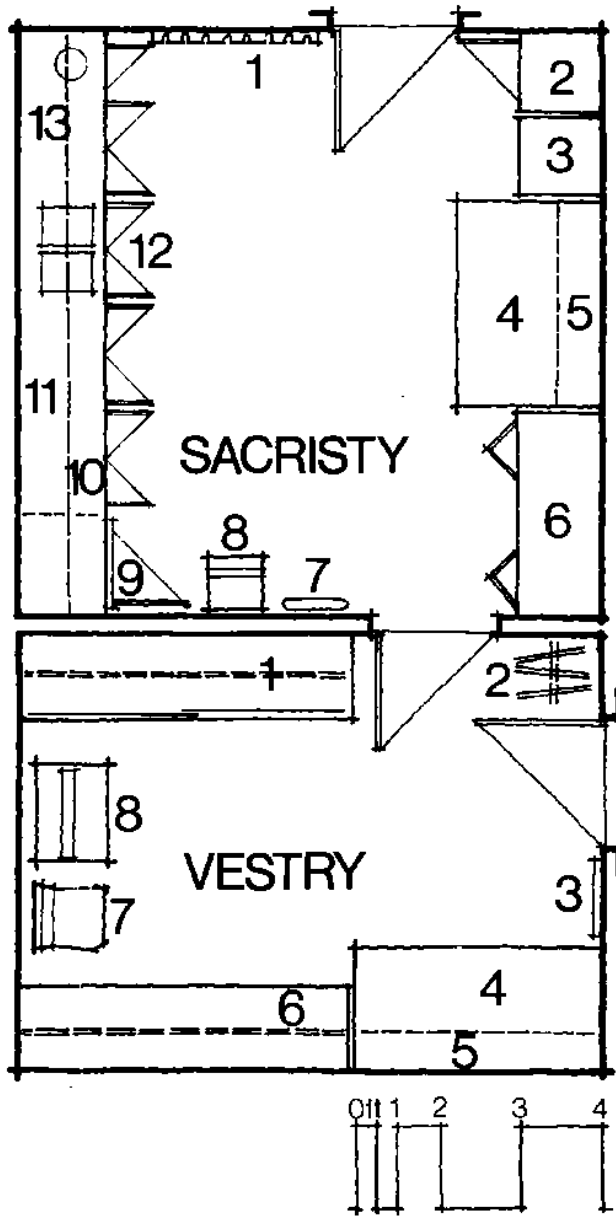

LEGEND

SACRISTY

1. Bracket for Torches and Processional Devices, etc.
2. Locker
3. Bank of Drawers 5 ft (1525 mm) high
4. Work Surface 36 inches (900 mm) high with Large Shallow Drawers
5. Bookshelf
6. Case for Hanging Large Fabrics on Rods
7. Ironing Board
8. Step Stool
9. Refrigerator, Lockable
10. Counter with Lockable Doors
11. Wall Cabinets, Lockable
12. Sink
13. Sacrarium with Cover

VESTRY

1. Vestment Hanging
2. Street Clothing
3. Full Length Mirror
4. Layout Surface with Shallow Drawers Below
5. Bookshelf
6. Vestment Hanging
7. Chair
8. Prie Dieu

TITLE

Typical Scheme for Sacristy and Vestry

DATE

11/83

FACILITY PLATE NO.

Chapel: 730-83
Rel. Educ. Fac.:
730-84

SHEET

19

PAGE 78 INTENTIONALLY BLANK

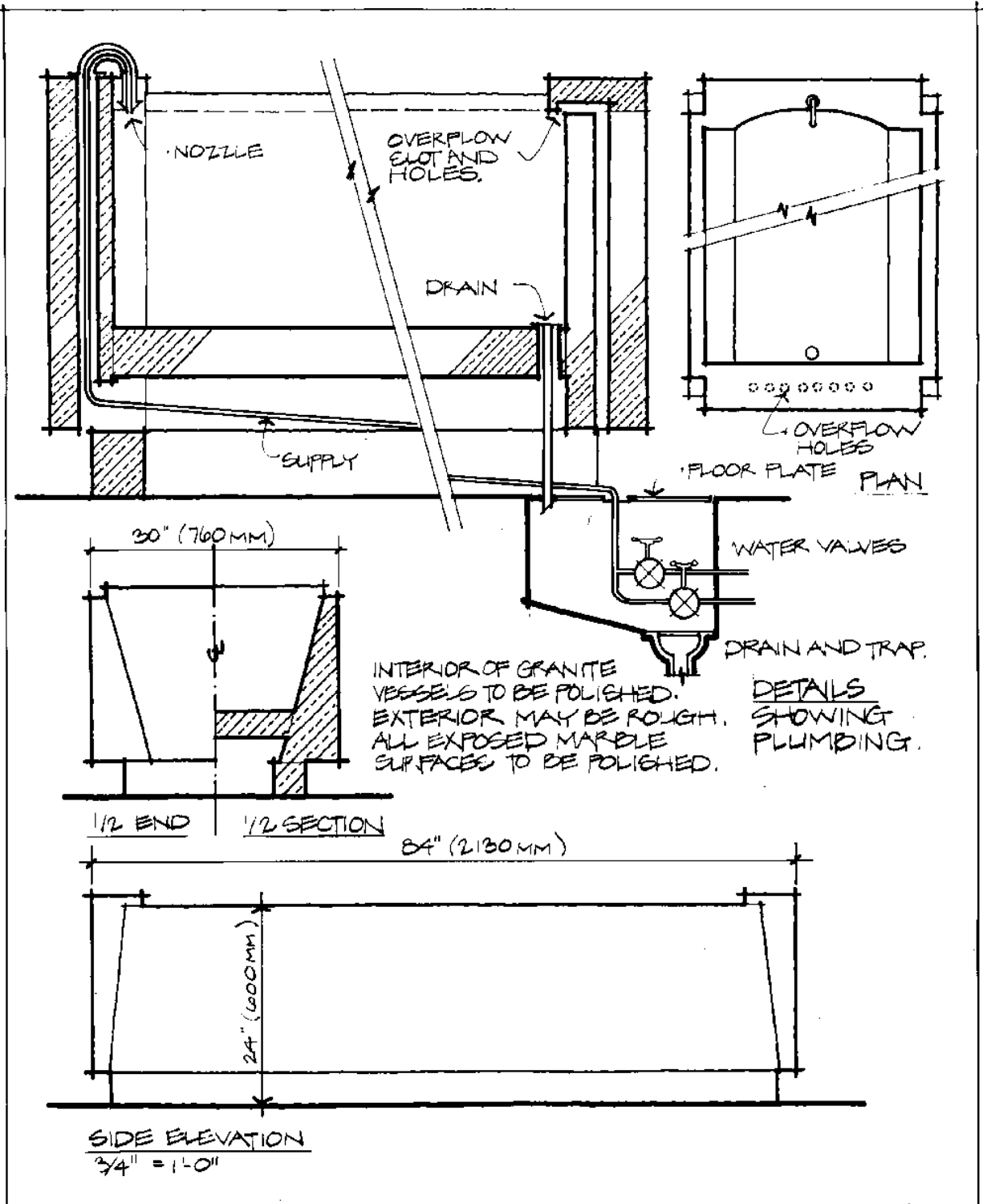

TITLE	DATE	FACILITY PLATE NO.	SHEET
Typical Baptismal Vessel	11/83	Chapel: 730-83 Rel. Educ. Fac.: 730-84	20

37.06-79

PAGE 80 INTENTIONALLY BLANK

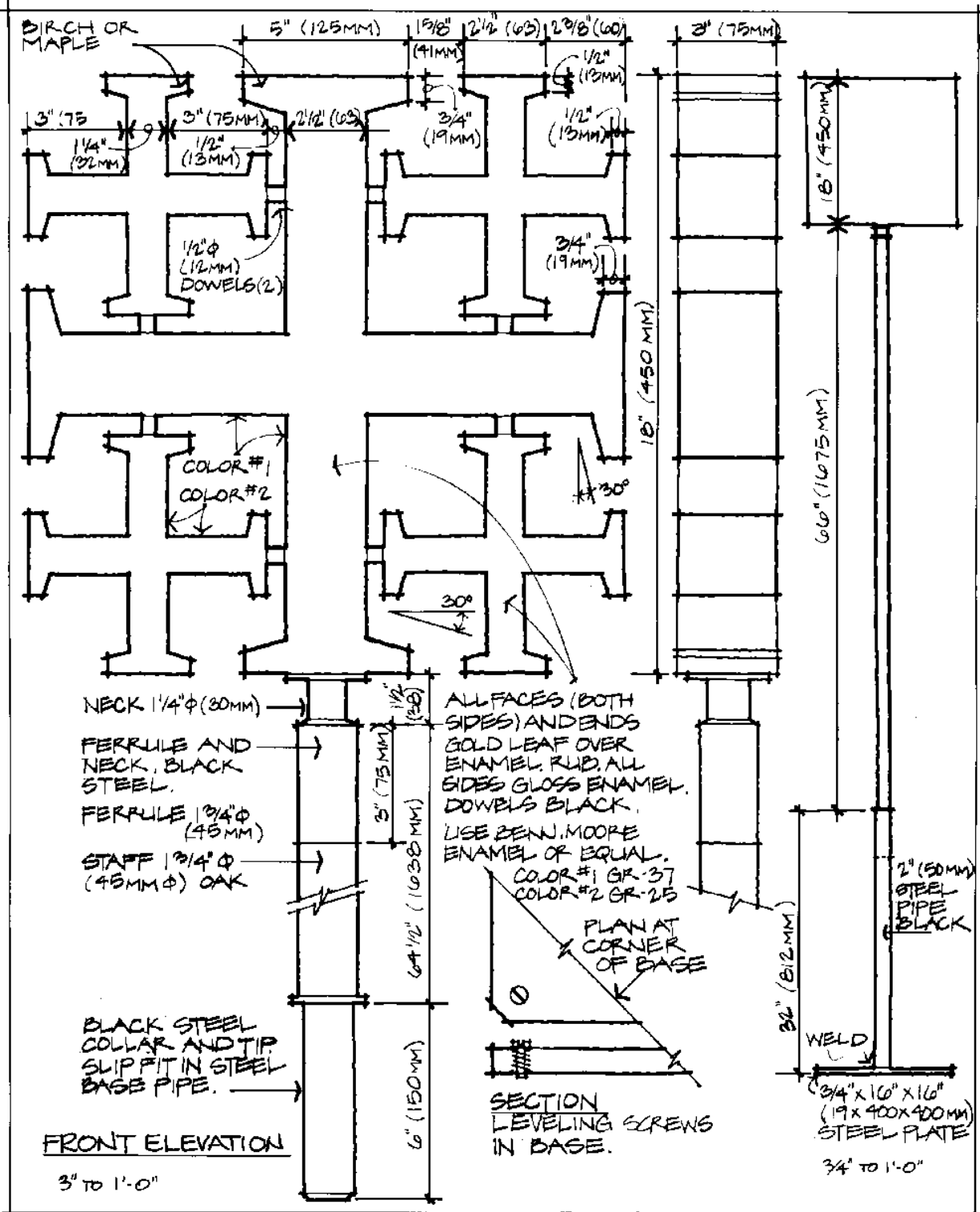

TITLE	DATE	FACILITY PLATE NO.	SHEET
Processional Cross	11/83	Chapel: 730-83 Rel. Educ. Fac.: 730-84	21

PAGE 82 INTENTIONALLY BLANK

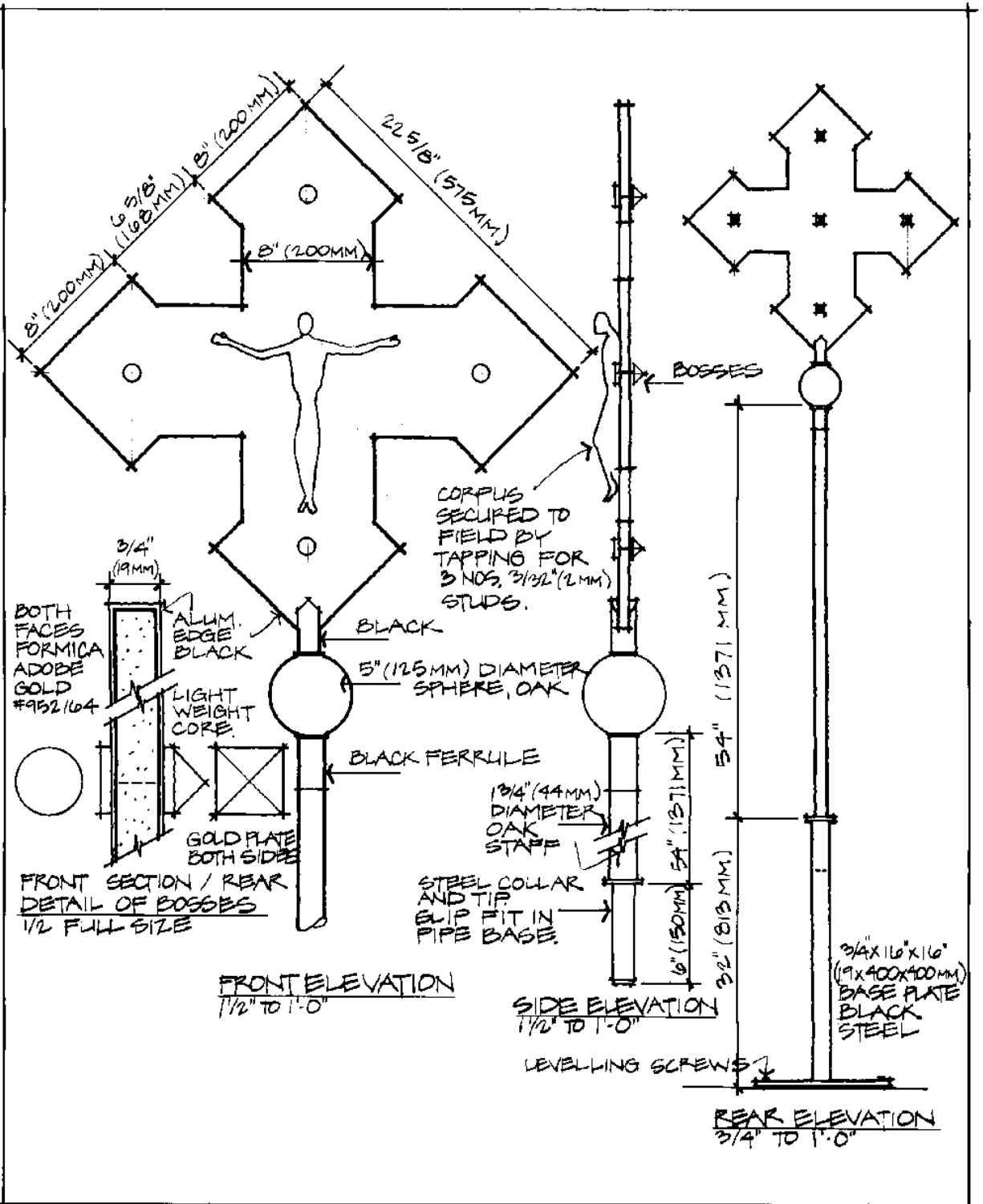

TITLE	DATE	FACILITY PLATE NO.	SHEET
Processional Cross	11/83	Chapel: 730-83 Rel. Educ. Fac.: 730-84	22

PAGE 84 INTENTIONALLY BLANK

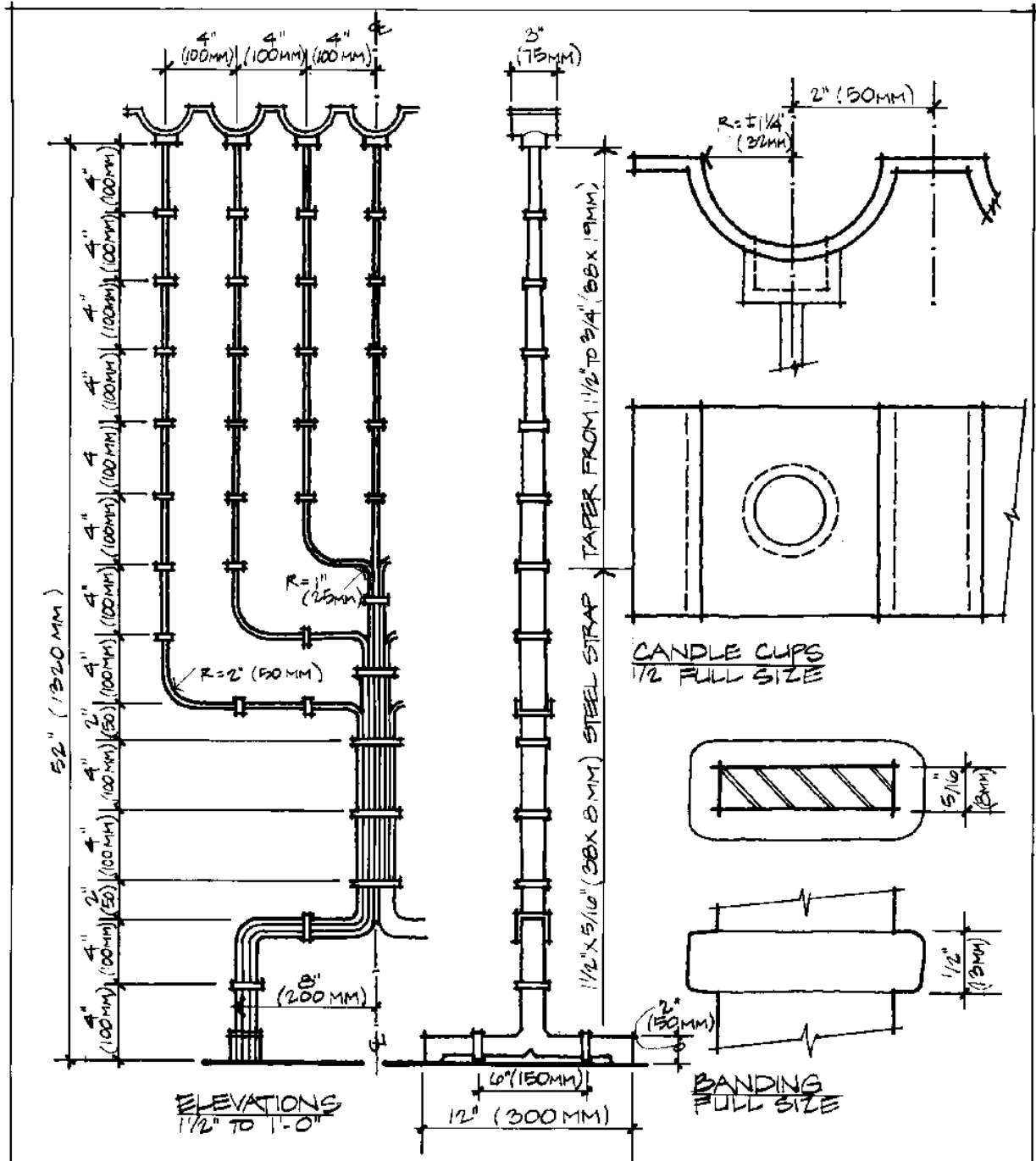

MATERIALS: STEEL, HAND HAMMERED BLACK, BANDING IS BRONZE COATED, CUPS ALSO.
 ALTERNATE: STEEL, NO HAMMERING, COAT ALL SURFACES WITH BRONZE, USING TORCH.

TITLE	DATE	FACILITY PLATE NO.	SHEET
Menorah	11/83	Chapel: 730-83 Rel. Educ. Fac.: 730-84	23

PAGE 86 INTENTIONALLY BLANK

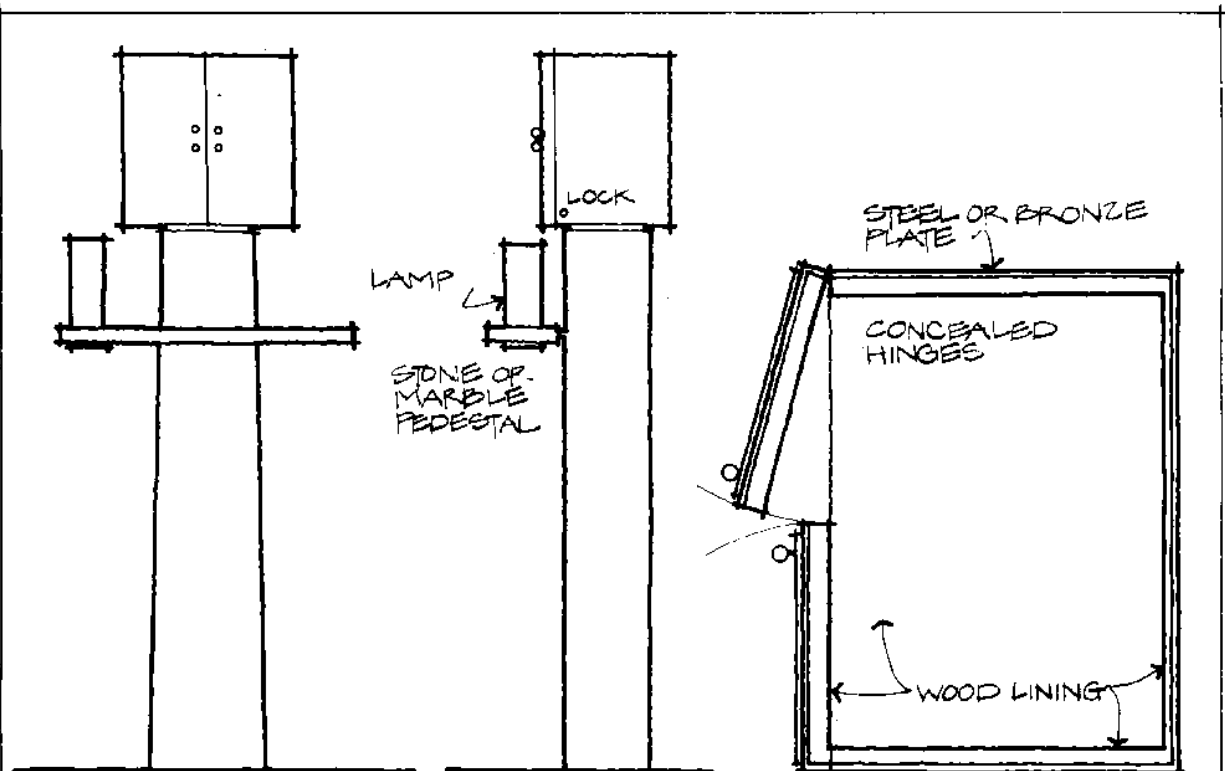

ELEVATIONS 11/16" TO 1'-0"

HORIZONTAL SECTION

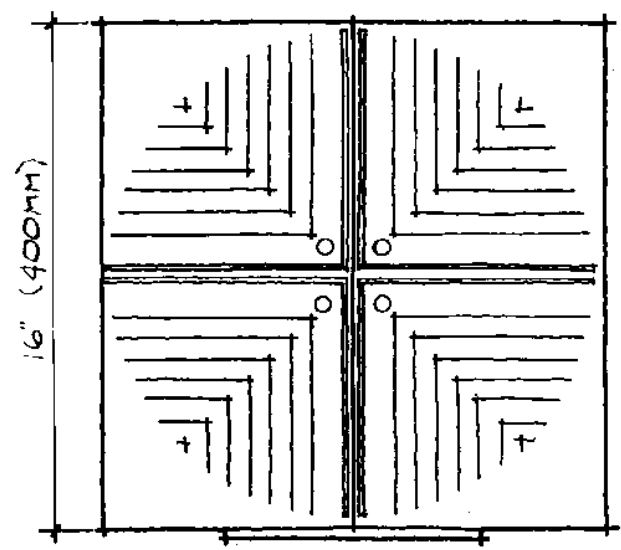

FRONT ELEVATION 3/16" TO 1"
DECORATIVE DETAIL IS BRASS OR GOLD PLATED WIRE.

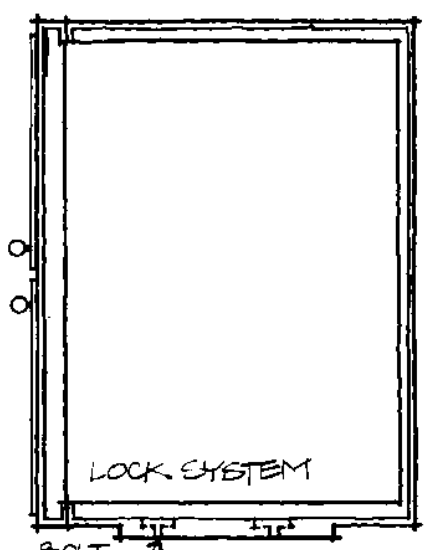

LOCK SYSTEM
BOLT
VERTICAL SECTION

TITLE	DATE	FACILITY PLATE NO.	SHEET
Typical Tabernacle with Pedestal and Lamp	11/83	Chapel: 730-83 Rel. Educ. Fac.: 730-84	24

PAGE 88 INTENTIONALLY BLANK

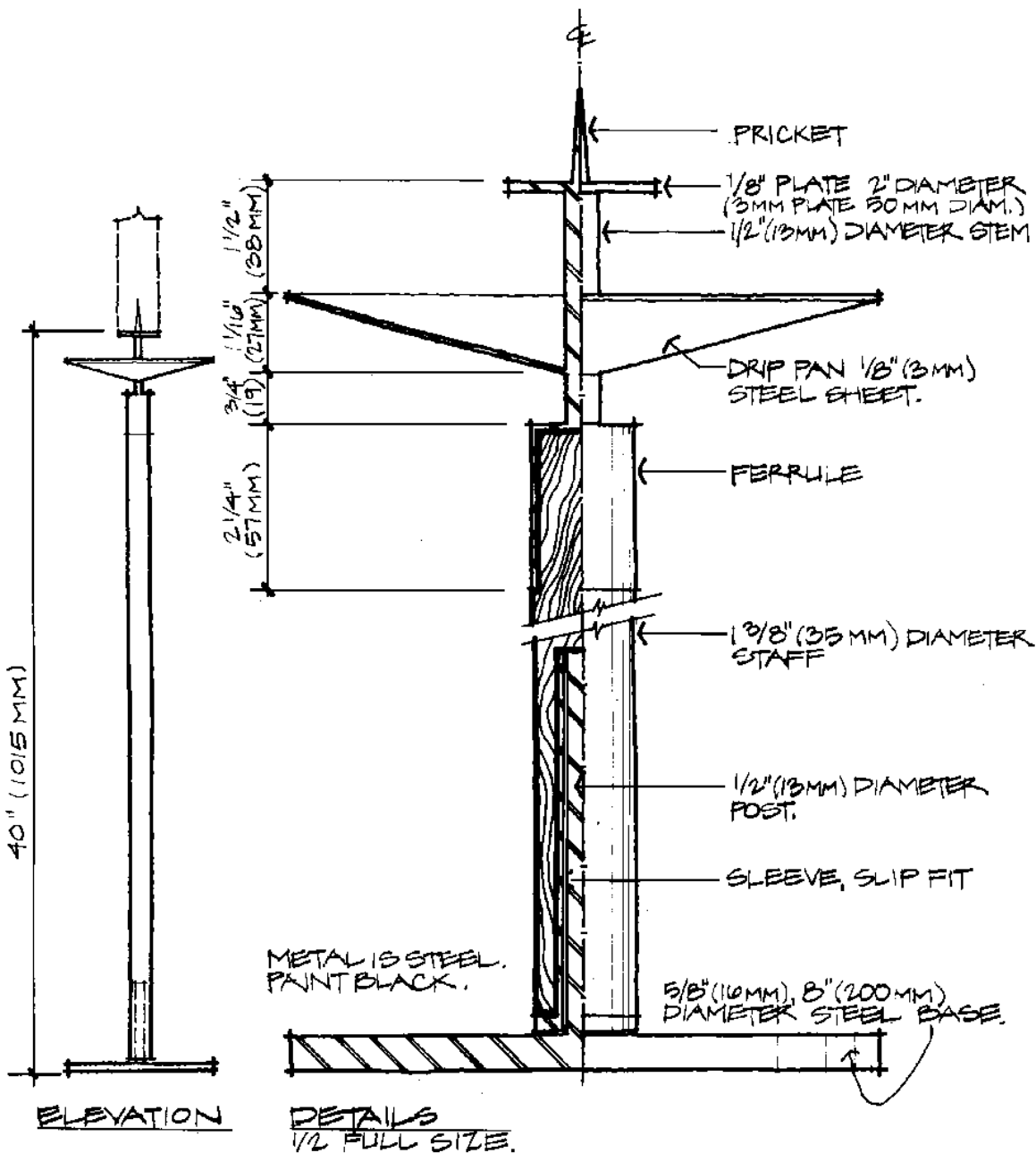

TITLE	DATE	FACILITY PLATE NO.	SHEET
Portable Floor Standing Candlesticks	11/83	Chapel: 730-83 Rel. Educ. Fac.: 730-84	25

PAGE 90 INTENTIONALLY BLANK

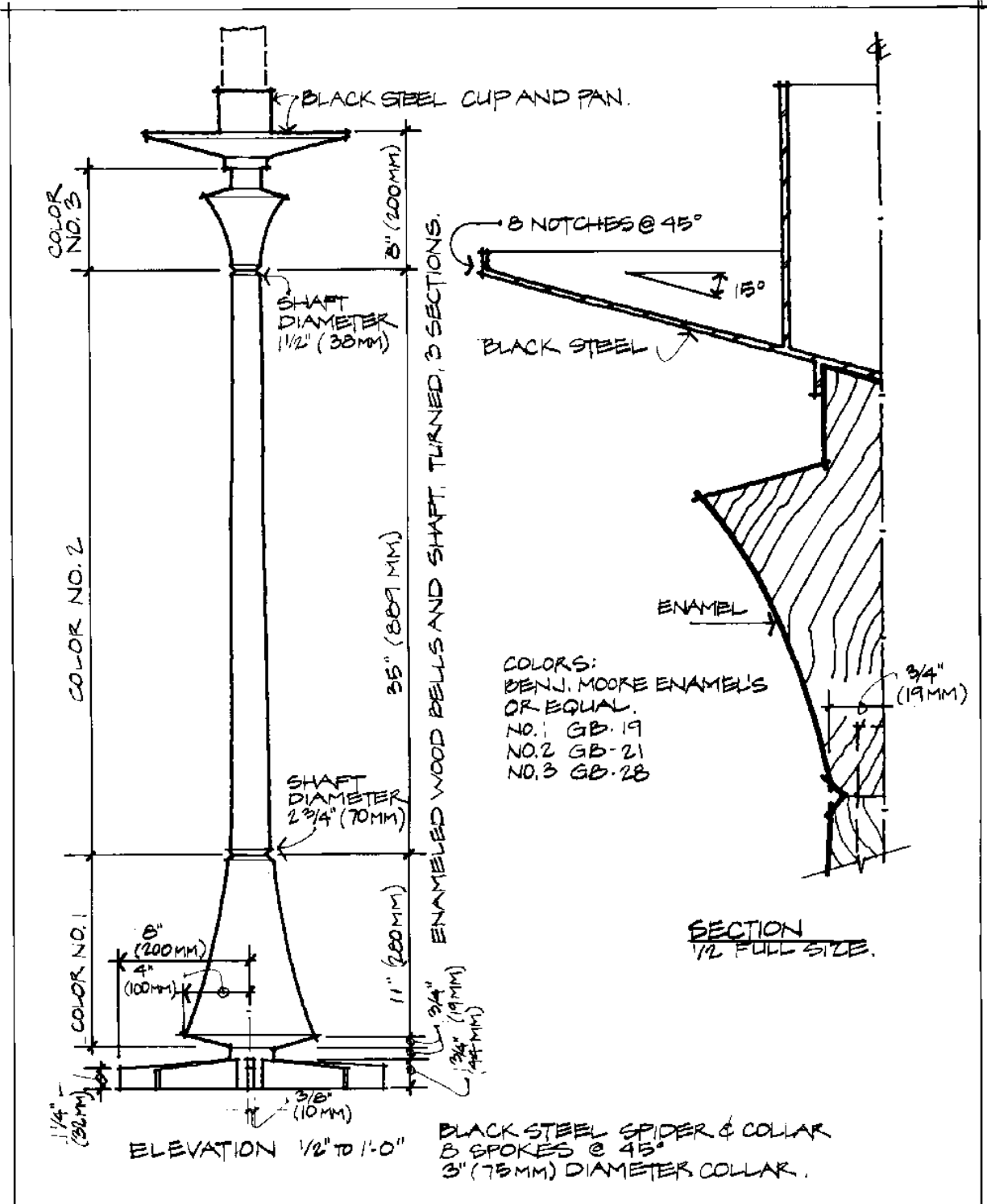

TITLE	DATE	FACILITY PLATE NO.	SHEET
Pascal Candlestick	11/83	Chapel: 730-83 Rel. Educ. Fac.: 730-84	26

PAGE 92 INTENTIONALLY BLANK

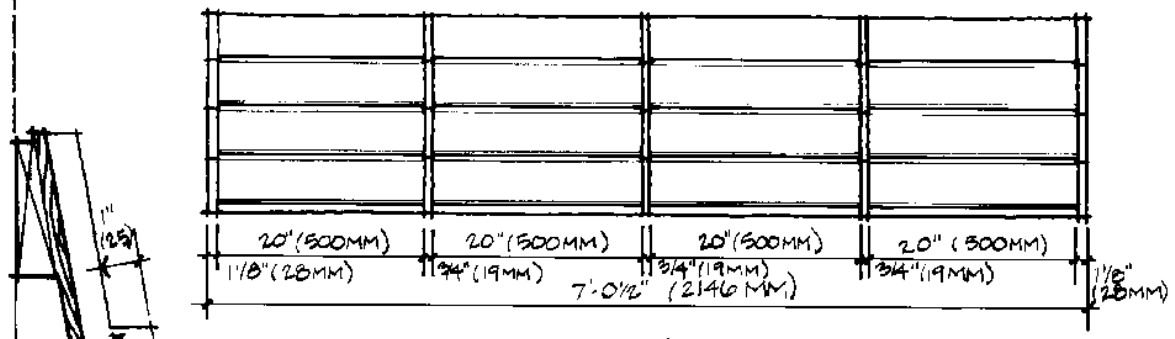

FRONT ELEVATION

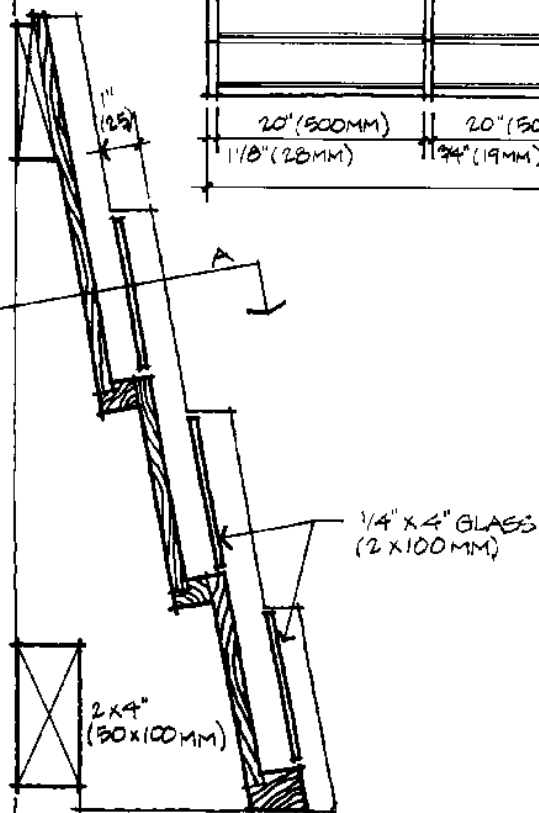

VERTICAL SECTION
1/4 FULL SIZE

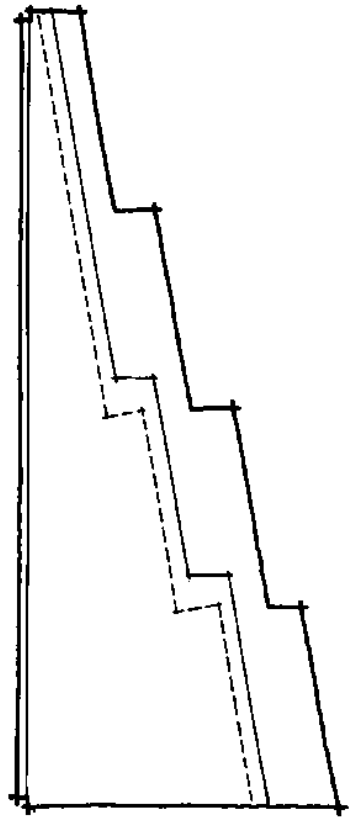

END ELEVATION
1/4 FULL SIZE

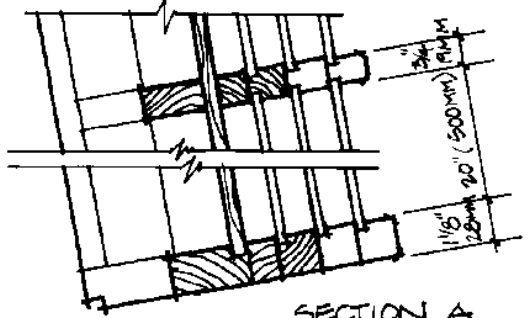

SECTION A
1/4 FULL SIZE

TITLE	DATE	FACILITY PLATE NO.	SHEET
Tract Rack	11/83	Chapel: 730-83 Rel. Educ. Fac.: 730-84	27

PAGE 94 INTENTIONALLY BLANK

TABLE 3
Typical Utility Requirements

Facility	100 Seat Chapel with Rel. Ed. Fac.		300 Seat Chapel with Rel. Ed. Fac.		500 Seat Chapel with Rel. Ed. Fac.	
Area	7,000 sq.ft. 650 m ² J		13,250 sq.ft. 1,230 m ² J		21,000 sq.ft. 1,930 m ² J	
Electrical load	no A/C	with A/C	no A/C	with A/C	no A/C	with A/C
Connected KVA	61.0	101.1	99.6	208.3	143.0	304.
Est. demand KW	55.0	118.9	89.7	177.1	128.7	258.
Water (no fire protection)						
Total demand	35 gpm (132 Lpm)		40 gpm (150 Lpm)		52 gpm (195 Lpm)	
Hot water demand	145 gph (547 Lph)		250 gph (940 Lph)		325 gph (1230 Lph)	
* Hot water storage	120 g (440 L)		85 g (320 L)		170 g (642 L)	
Heating						
Outside temp.	20 deg.F	(-7 deg.C)	20 deg.F	(-7 deg.C)	20 deg.F	(-7 de
Inside temp.	170 deg.F	(21 deg.C)	70 deg.F	(21 deg.C)	70 deg.F	(21 de
Max. BTU/hr.	299,300		519,400		781,500	
Cooling						
Outside temp.	93 deg.F	(34 deg.C)	93 deg.F	(34 deg.C)	93 deg.F	(34 de
Inside temp.	78 deg.F	(26 deg.C)	78 deg.F	(26 deg.C)	78 deg.F	(26 de
Max. BTU/hr.	342,500		648,800		969,900	

The above data re for estimating purposes. They assume a hypothetical location at Norfolk, VA for each of the four facilities used as typical in this manual. 20% glass area is assumed.

* The apparent inconsistency in the relative capacities of hot water storage derives from efficiencies in heating units; low requirements may best be met with small heating units and larger tanks.

REFERENCES

Chief of Naval Operations Instructions

OPNAVINST 5430.48

Department of Defense (DOD) Manual, The Pentagon, Washington, D.C. 20301

DOD 4270.1-M Construction Criteria Manual

Facilities Planning Factors Criteria for Navy and Marine Corps Shore Installations

NAVFAC P-80

National Fire Protection Association (NFPA) Standards, Batterymarch Park, Quincy, MA 02269

NFPA 101 Life Safety Code

NAVFACENGCOM Design Criteria

DM-1 Series	Architecture
DM-2 Series	Structural Engineering
DM-3 Series	Mechanical Engineering
DM-4 Series	Electrical Engineering
MIL-HDBK 1008	Fire Protection for Facilities Engineering, Design and Construction
DM-14 Series	Interior Design

Project Engineering Documentation (PED)

NAVFACINST 11010.14M Proposed Military Construction Projects

Department of Defense activities may obtain copies of Design Manuals and P-Publications from the Commanding Officer, Naval Publications and Forms Center, 5801 Tabor Avenue, Philadelphia, PA 19120. Department of Defense activities must use the Military Standard Requisitioning and Issue Procedure (MILSTRIP), using the stock control number obtained from NAVSUP Publication 2002.

Other Government Agencies and commercial organizations may procure Design Manuals and P-Publications from the Superintendent of Documents-, U.S. Government Printing Office, Washington, DC 20402.

Instructions and NAVFAC Guide Specifications are available to all parties, free of charge, from the Commanding Officer, Naval Publications and Forms Center, 5801 Tabor Avenue, Philadelphia, PA 19120; telephone-. Autovon (DoD only): 442--3321; Commercial: (215) 697-3321.

INDEX

A	Page	E	Page
Acoustics, chapel.	6-28	Ethics, symbolized in architecture	6-5
B			
Baptismal vessels	6-17, 6-33, 6-79	I	
Beauty, as symbol of the holy	6-4, 6-40	Islamic worship, provision for	67-18, 6-19
Brides' room	6-23	J	
C			
Chapels, Navy and Marine Corps		Jewish worship, provision for (see Liturgical Furnishings)	
Acoustics	6-28	K	
Architectural character.	6-4, 6-13, 6-14	Kosher kitchen	6-25
Area assignments	6-10, 6-11	L	
Audio/visual	6-12, 6-22, 6-29	Liturgical arts consultants	6-5
Design factors	6-13--6-27	Liturgical arts and Furnishings	
Flexible function	6-4, 6-5, 6-8	Christian usage	6-15--6-17, 6-71, 6-75, 6-79--6-87, 6-91
Furnishings (see Liturgical furnishings)		Fabrics	6-18, 6-19, 6-40
Interfaith character	6-3	Islamic usage	6-18, 6-19
Lighting	6-30--6-32	Itemization	6-34--6-37
Mechanical systems	6-32, 6-33, 6-95	Jewish usage	6-18, 6-38, 6-71, 6-73, 6-85
Musical provisions	6-10, 6-14, 6-22	Nonsectarian provisions	6-3, 6-12
Planning	6-6--6-12, 6-41--6-67, 6-77	Procurement	6-33--6-37
Platforms for	6-15, 6-69	R	
Seating	6-14	Reconciliation rooms.	6-8, 6-20
Sitting	6-6, 6-7	Religious program	
Chapel of Reservation	6-5, 6-8, 6-10, 6-20	Intentions	6-2
Chapels for hospitals.	6-11, 6-12	Nonsectarian character	6-3
Child Care	6-3, 6-23, 6-26	Services.	6-2
Chaplain		Religious education	
Activities	6-2	Directors' offices	6-8, 6-23, 6-27
Offices	6-23	Scope of.	6-2, 6-26
Christian worship, provisions for (See Liturgical Furnishings and Arts)		Spaces for.	6-8, 6-10, 6-11, 6-25--6-27, 6-41, 6-43, 6-47, 6-49, 6-53--6-57, 6-65, 6-67

INDEX

S	Page
Sacristy	6-21, 6-22, 6-77
Social halls in chapels . .	6-2,
6-8, 6-10, 6-11, 6-24, 6-25	
Stained glass	6-30
Symbolism religious (see Liturgical arts and furnishings)	
T	
Truth, symbolized in architecture	6-4
V	
Vestry	6-21, 6-22, 6-77